

## WS/R Rain Detector



### Description

The WS/R rain detector is suitable for outdoor use. The sensing part of the probe is an etched area which consists of three carbon electrodes separated by a waterproof resin. The sensing area is smooth to allow water droplets to run off more easily and it should be mounted at a 30° to 40° angle to assist this. The unit also incorporates a heating element to dry off the surface wetness once rainfall has ceased. This heater can be run continuously using a special power supply, or can be powered from an IQ controller. It can be used as part of a control strategy for window-louvre opening in naturally ventilated buildings.

### Features

- Etched carbon electrodes.
- IP67 housing.
- 0 to >1 Vdc output.
- ON/OFF detection of rain.
- Smooth sensing area and heating element for fast response.
- Heater can be controlled from IQ controller.
- Suitable for naturally ventilated building applications.

### Physical

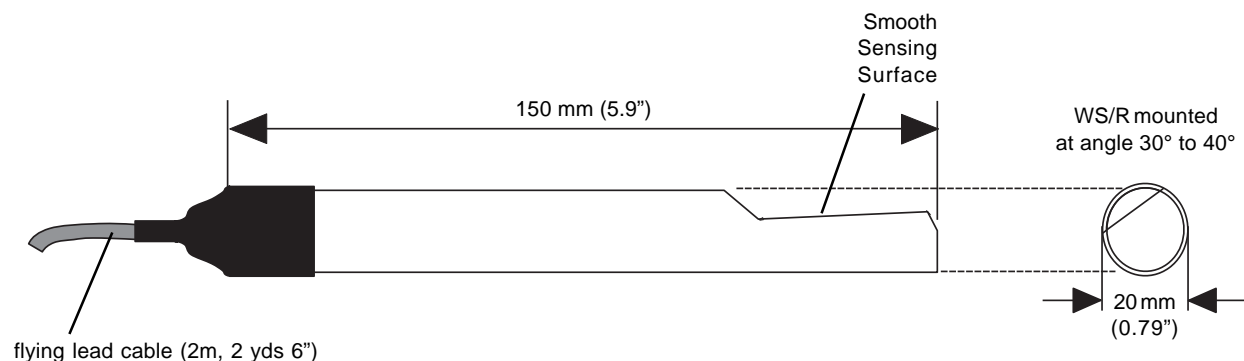

## APPLICATION

The WS/R Rain Detector is designed to detect rainfall. It does not measure the amount of rain, but provides an immediate indication of precipitation for the control of automatic windows or louvres in buildings or atria.

It utilises the principle of conduction between three carbon electrodes on a flat sensing surface; the electrodes are separated by waterproof resin.

Beneath the sensing surface is embedded a 100  $\Omega$ , 5 W ceramic resistor; the resistor is used to heat the sensor to prevent condensation on the probe's surface. Passing a 120 mA current through the heater raises the temperature of the sensing surface by 20 to 30 °C (68 °F to 86 °F) above the air temperature and prevents dew forming on the sensor surface.

The sensor should be mounted at an angle of 30 to 40 ° to enable surplus rain to run from the surface and help the sensor to dry more rapidly when the rain has stopped.

In time the sensing surface may become contaminated (indicated by a permanently wet signal). The surface should be cleared by scrubbing with a toothbrush or similar lightly abrasive brush.

Note that the nominal sensor supply is 9 to 12 Vdc, but the sensor is fully functional with a 24 Vdc supply.

### INSTALLATION

The sensor should be mounted in a location providing safe access for maintenance and a suitable operating environment.

- (1) Mount the sensor in position.
- (2) Wire sensor's power supply and output.

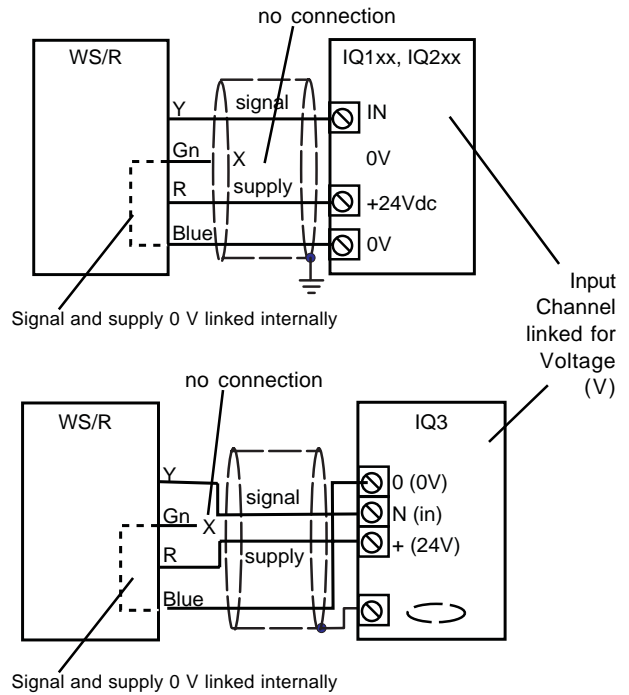

- (3) Connect the power to the sensor's heater supply.

WS/R powered from IQ controller

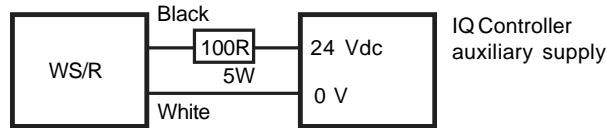

WS/R powered from external 12 V supply

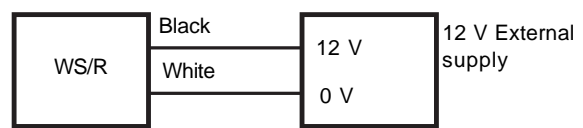

When powering the sensor's heater from an IQ controller's 24 V auxiliary supply it is necessary to connect a 100 Ω, 5 W resistor in series with the sensor.

- (4) Configure controller to detect the sensor voltage change.

Full details are given in the WS/R Installation Instructions TG102665.

### DISPOSAL



**WEEE Directive :**

At the end of their useful life the packaging and product should be disposed of by a suitable recycling centre.

Do not dispose of with normal household waste.

Do not burn.

### ORDER CODES

	USA order Code	
<b>WS/R</b>	882003300	Rain Detector

**SPECIFICATIONS**

**Electrical**

Power requirements :9 to 24 Vdc @ 5 mA  
 Heater power supply :12 Vdc @ 120 mA OR 24Vdc at 120 mA from IQ auxiliary supply connected via 100 Ω, 5 W resistor.  
 Output :0 to >1 Vdc (0 V = no rain, >1 V = rain is present) (rain present is indicated by >100 on IQ if setup as above)

**IQ Scaling**

It is recommended to use SET (Software Tool) for the setting of sensor type modules. For all IQ2 series controllers with firmware of version 2.1 or greater, or IQ3 series controllers the following SET Unique Sensor Reference should be used:

**Rain Detector V**

Alternatively select sensor type module scaling mode 5, (characterise) and enter scaling manually as defined in the table below. For all other IQ controllers see the Sensor Scaling Reference Card, TB100521A.

Y	E	U	L	P	I <sub>1</sub>	I <sub>2</sub>	O <sub>1</sub>	O <sub>2</sub>
0	4	1000	-1	2	0	10	0	1000

volts, V

**Mechanical**

Dimensions :150 mm (5.9") x 20 mm (0.79") diameter  
 Sensing area :15 mm (0.59") x 30 mm (0.12")  
 Weight :150 g (5.28 oz)  
 Cable length :2 m (2 yds 6")

**Environmental**

Operating range :-25 to +55 °C (-13 °F to 131 °F)  
 Storage range :-25 to +55 °C (-13 °F to 131 °F)  
 Protection rating :IP67

Manufactured for and on behalf of the Environmental and Combustion Controls Division of Honeywell Technologies Sàrl, Ecublens, Route du Bois 37,Switzerland by its Authorized Representative.

Trend Control Systems Limited reserves the right to revise this publication from time to time and make changes to the content hereof without obligation to notify any person of such revisions or changes.

**Trend Control Systems Limited**

P.O. Box 34, Horsham, West Sussex, RH12 2YF, UK. Tel:+44 (0)1403 211888 Fax:+44 (0)1403 241608 www.trend-controls.com

**Trend Control Systems USA**

6670 185th Avenue NE, Redmond, Washington 98052, USA. Tel: (425)897-3900, Fax: (425)869-8445 www.trend-controls.com