

FUNCTIONALITY

The PNC2 interfaces between a printer connected via the RS232 port and the IQ system Lan; it also provides certain network maintenance operations. It allows messages such as alarms to be printed out. Alarms intended for the printer are simply sent to the PNC2 which in turn passes them to the printer. The PNC2 continually monitors the Lan; if it receives data that is addressed to a different node it passes it on around the Lan via its transmit port. If it receives data for its own address, it will transmit it to the RS232 port.

The PNC2 also monitors Lan integrity by performing continuous checking of network messages. Alarm messages are generated whenever a problem occurs.

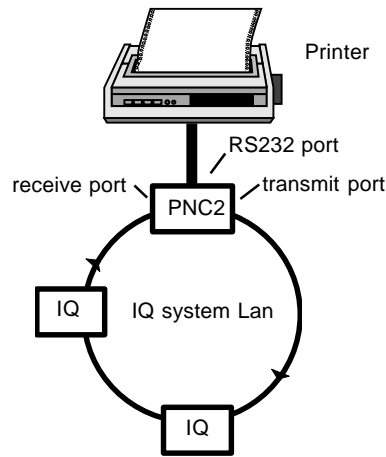



HARDWARE

Packaging: The PNC2 can be provided boxed, or as a board version.

Boxed version: The PNC2 can be supplied in a plastic enclosure with a transparent plastic flip-up terminal cover (NBOX/PNC2/...). It has 3 point mounting to facilitate installation. There is an optional battery backup to keep the node functioning in the event of mains failure (NBOXB/PNC2/230 - 230 Vac version only). An optional metal enclosure with cable gland knockouts is available (ENCLS/MBOX/IQ22x).

Board version: The board version will fit inside certain IQ controllers. The controllers can be ordered pre-fitted with the node (e.g. IQ241/PNC2/...), or the node can be retrofitted by using the appropriate fitting kit (KIT/node/IQ23x for IQ231/233 KIT/node/IQ24x for IQ241/242, or KIT/node/IQ25x for IQ250/251).

Network : The two part network terminals are for 2 wire cables. The standard IQ system node features are included (Lan OK, Tx, Rx indicators, bypass relay, network alarm generation).

Address Switch : The PNC2 device address on the local Lan is selected by address switch poles 1 to 7. It may be set in the range 1, 4 to 9, 11 to 119 and must be unique on the local Lan.

Dumb/Normal Switch: The dumb/normal switch setting (SW1, pole 8) is used to select the printer interface (RS232 port, Device B) comms type as follows:

- Dumb: 8 bits no parity
- Norm: 7 bits odd parity

The default factory setting is Norm (7 bits odd parity).

The PNC2 will only operate on a network+, post 1985 Lan.

Baud Rate Links : The local Lan and printer (RS232) baud rates are set by two sets of links to 19k2, 9k6, 4k8, or 1k2. The local Lan baud rate must be set to match other nodes on the local Lan. The RS232 port baud rate must match the printer.

Network bypass relay : In order that the network continues to operate if the PNC2 fails, a node bypass relay is fitted to maintain network integrity in the event failure of the node's power supply, of failure of the node itself. The bypassing of a node will be recognised by the downstream node, and reported as a Lan Changed alarm.

Power: The boxed version (NBOX/PNC2/..) can be supplied in 230 Vac and 24 V(ac or dc) versions. The battery backed boxed version (NBOXB/PNC2/230) is only supplied in 230 Vac version. The 230 Vac versions are supplied with an optional supply terminal shroud.

The board version requires 24 Vdc, or 18 Vac (transformer isolated), or 18-0-18 Vac (transformer centre tapped)

Fusing: No replaceable fuses are fitted. Protection is provided by a self-resetting thermally protected transformer. The 24 V version is protected by a self-resetting PTC device.

RS232/Lan connections: The printer connection is referred to as the RS232 port on the NBOX version, and as the Device B connection on the board version. The IQ system Lan is referred to as Lan A.

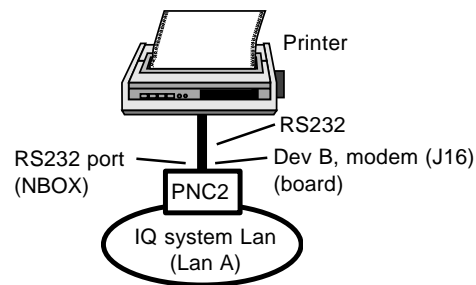

The local Lan (Lan A) connection is duplicated on the PNC2 board as the Device A RS232 connection (J15). If an RS232 device were to be connected to the RS232 connector (Dev A), the Lan connection (Lan A) would be effectively disconnected.

Printer: The printer must be able to accept Epson type control codes, and have an RS232 serial interface with the following settings:

Baud rate: 19k2, 9k6, 4k8 or 1k2 (PNC2 printer baud rate link must be set appropriately).

Serial/Parallel: Must be set up as a serial printer.

Comms type: can be either of the following and the dumb/normal switch must be set appropriately:

8 bits no parity (dumb/norm switch set to dumb)

7 bits odd parity (dumb/norm switch set to norm)

e.g. if dumb/norm is norm the printer must be set to:

- parity selected on/off =on,
- parity odd/even=odd,
- data bits 7/8=7.

Auto Line Feed: Must be switched on. (962 doesn't need this; if set will give two line feeds).

Battery backup: NBOXB/PNC2/230. 230 Vac version only. Rechargeable batteries maintain node operations for 20 minutes (typical) during mains failure. The on-board links J12 and J13 must be set 'on' to use and charge the battery. The unit must be powered on for at least 16 hours (with J12, J13 on) before the batteries will support the unit during mains failure

HARDWARE (continued)

Indicators: The PNC2 has 9 indicators to monitor unit status.

⚡ (Power) (green) On when supply is on (normally ON); if OFF, power fail.

⚠ (Watchdog) (red) On if a processor or software fault (normally OFF); if ON, PNC2 fail.

DTRA (yellow) PNC2 busy to local Lan, currently transmitting to printer (Lan A) (normally flashes).

CTSA (yellow) Not used.

DTRB (yellow) PNC2 busy to printer, unable to receive data from printer (RS232 port or Dev B). (normally flashes).

CTSB (yellow) Printer (RS232 port or Dev B) busy to PNC2, unable to receive data from PNC2.

TX (yellow) Monitors current flow from PNC2 to Trend Lan (Lan A). (normally ON). If OFF, transmit connection to next node may be broken.

RX (yellow) Monitors current flow to PNC2 from Trend Lan (Lan A). (normally ON). If OFF, receive connection from previous node may be broken or short-circuited.

OK (green) ON if local Lan (Lan A) OK. Flashes if prohibited Lan address (0, 2, 3, >119) set on address switch. OFF if Lan fault (e.g. baud rate conflict).

Connectors: Two part connectors are used throughout to facilitate wiring. A busbar is provided for screen termination (NBOX(B) only).

Use with LRM: The LRM (Latching Relay Module) can be used to drive an audible alarm or warning lamp when a message (e.g. alarm) is sent to the printer. A pushbutton connected to the LRM can be used to reset the alarm or lamp. The LRM is connected to J17 on the PNC2. The LRM +/- link should be in the + position.

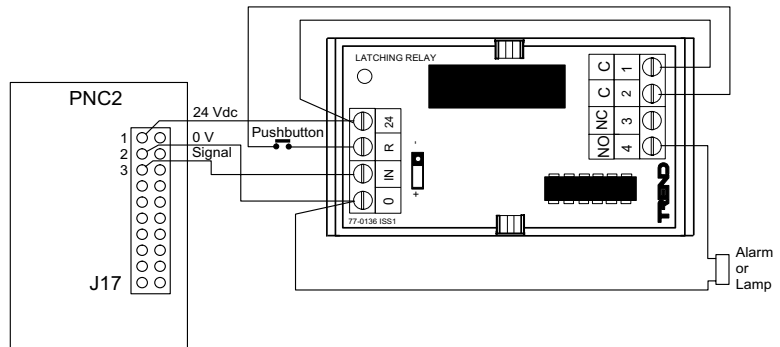

FIRMWARE

Reset: The PNC2 will reset itself on power up, or on change of address or baud rate.

Alarms: The PNC2 also helps to maintain a high level of network integrity by performing continuous checking of network messages. The following alarms are generated when faults are found:

- “Local LAN reported by xxx -
 - Lan Broken NKBK**” - a break in communications over the local Lan.
 - Lan OK NKOK**” - local Lan communications are restored.
 - Lan Changed NKCH**” - a node has gone from or been added to the local Lan.
 - Duplicate Address NKDA**” - another node on the local Lan has the same address as this PNC2. Checked after a reset or any network build caused by another device on the network.

It will deliver these alarms to the RS232 port local device in the format required by the printer (text).

Text Comms: The PNC2 will support the following text comms:
R(P) Alarm language type, read/write. Sets alarm language where P= 0 to 9, e.g. R(P=0) sets English, see below.
R(D), read only, Identifier i.e. 'PNC2'
R(C), read only, Version number e.g. 'V5.10 28/02/01'

Alarm Language: Network alarm messages are available in 10 languages, and can be set and monitored by text comms, R(P=x) will set language as below:

x=	0	English
	1	Spanish
	2	Finnish
	3	Swedish
	4	Norwegian
	5	Danish
	6	German
	7	Italian
	8	Portuguese
	9	French

The PNC2 will automatically detect the Lan language on reset. It will investigate what addresses are used on its own Lan, and then send a message (interrogating the language used) to each address in turn, starting with the lowest address. When it finds a language being used it will set its own language to be the same.

INSTALLATION

If the PNC2 is supplied as a board it must first be mounted in a suitable enclosure (e.g. certain IQ controllers, NBOX). It is normally mounted on 4 pillars. The NBOX(B)/PNC2 must be mounted on a flat surface via 3 off 6 mm (0.24") holes using screws and rawl plugs. The PNC2 installation involves the following procedure:

Fix the unit in position	Connect power supply
Route cables	Connect to printer
Connect the network	Connect Auxiliary Supply output (if used)
Set network address	Test
Set network baud rate	

A full description of installing the NBOX(B)/PNC2 is provided in the NBOX(B)/PNC2 Installation Instructions, TG200266. Instructions for installing a PNC2 board only are provided in the PNC2 Installation Instructions, TG200264.

The installation of an NBOX(B)/PNC2 using an ENCLS/MBOX/IQ22x is covered by ENCLS/MBOX/IQ22x Installation Instructions TG200204.

CONNECTIONS

Boxed NBOX(B)/PNC2

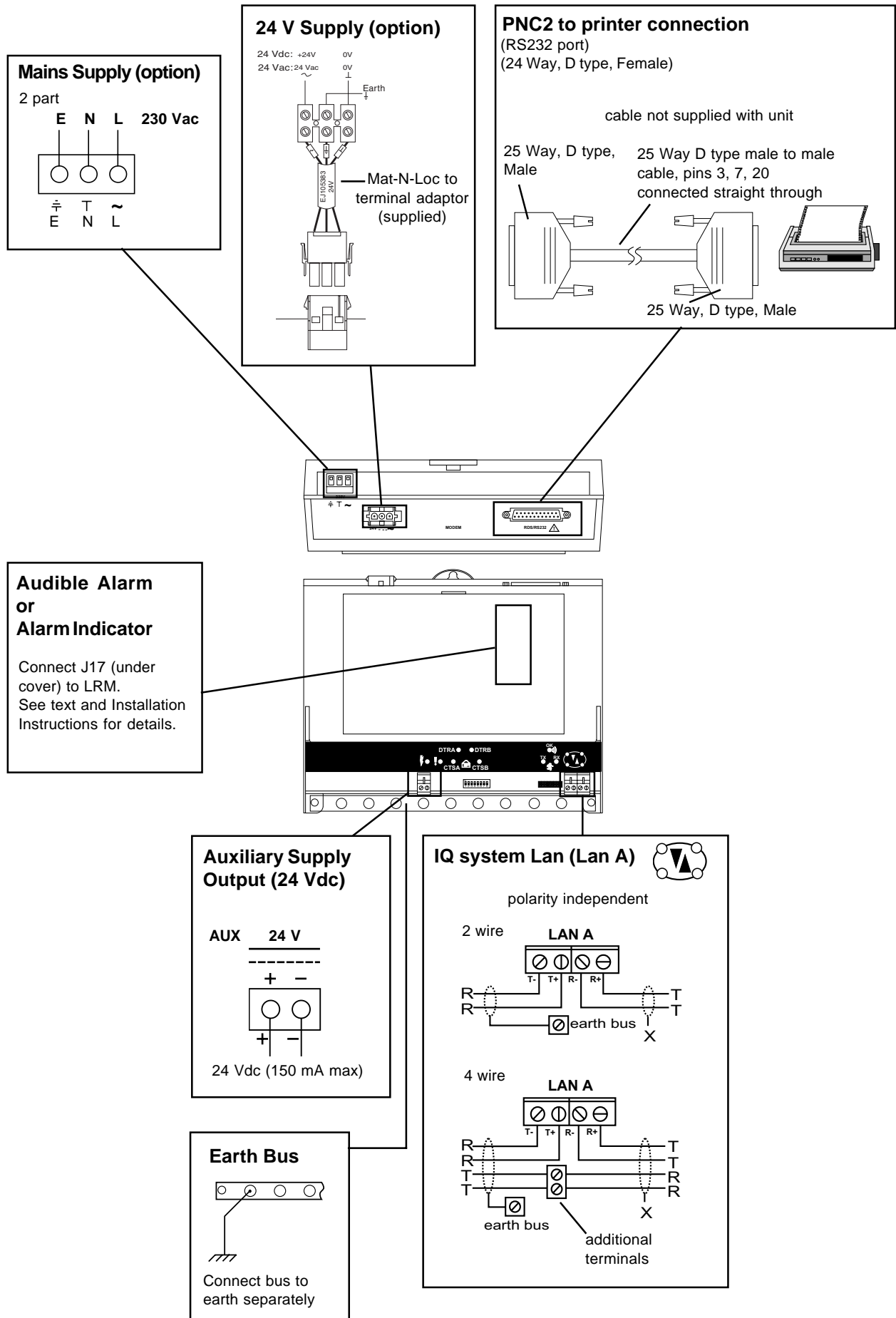

CONNECTION

Board PNC2

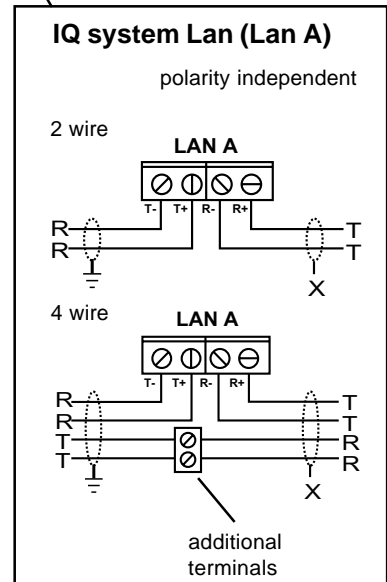
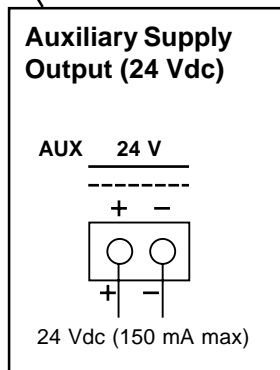
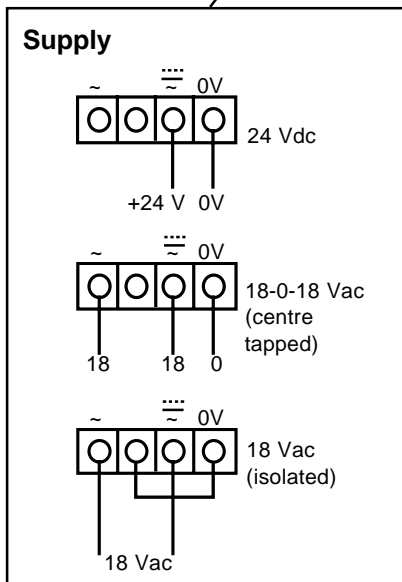
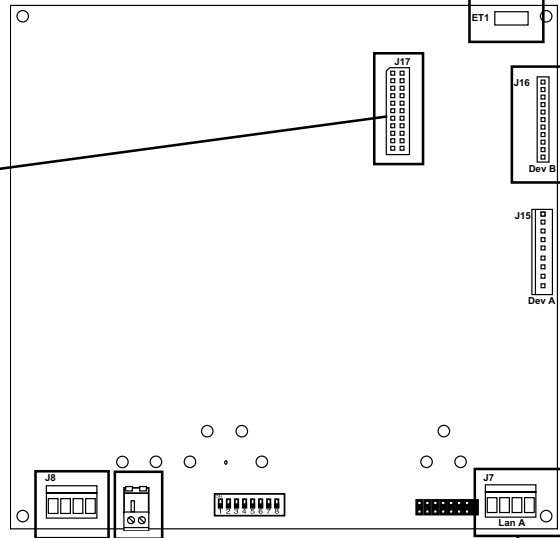
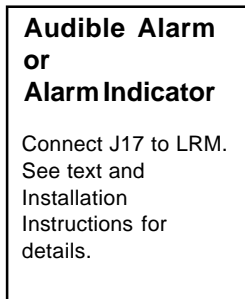
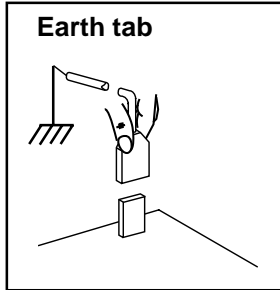
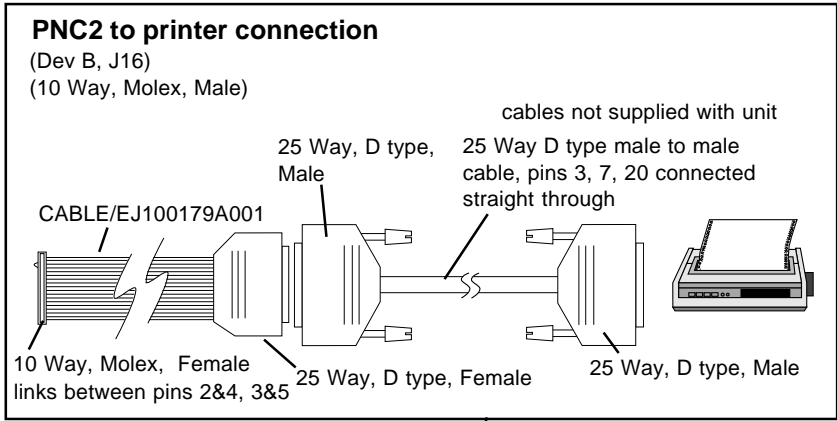

DISPOSAL

COSHH ASSESSMENT FOR DISPOSAL OF NODE CONTROLLER: No parts affected

RECYCLING

All plastic and metal parts are recyclable. The printed circuit board may be sent to any PCB recovery contractor to remove some of the components for any metals such as gold or silver.

ORDER CODES

- PNC2** Board only
- NBOX/PNC2/[power]** PNC2 in a NBOX plastic enclosure, including earth bus, earth bus screws, (230 Vac version is provided with mains terminal shroud)
- NBOXB/PNC2/230** Battery backed PNC2 in a NBOX plastic enclosure, including earth bus, earth bus screws, and mains terminal shroud

[power]	
230	230 Vac
24	24 Vac or 24 Vdc

- KIT/NODE/IQ25x** Fixings required to retrofit a node inside an IQ250/251 controller.
- KIT/NODE/24x** Fixings required to retrofit a node inside an IQ241/242 controller.
- KIT/NODE/IQ23x** Fixings required to retrofit a node inside an IQ231/233 controller.
- IQ2xx/PNC2/..** PNC2 fitted inside an IQ231, 233, 241, 242, 250, or 251 (e.g IQ241/PNC2/.. for PNC2 fixed in IQ241)
- ENCLS/MBOX/IQ22x** 261 x 285 x 77 mm IP30 enclosure for wall mounting NBOX/PNC2 with glanding and integral busbar
- CABLE/EJ100179A001** PNC2 board connector to RS232 device adaptor cable, 10 Way, Molex, Female to 25 Way, D type, Female
- TP/1/1/22/HF/200** 200 m of screened single twisted pair cable for use on IQ system Lan (or inputs/outputs). (Belden equivalent 8761NH).
- TP/2/3/22/HF/200** 200 m of screened twin twisted pair cable for use on IQ system Lan. (Belden equivalent 8723NH).

SPECIFICATIONS

Electrical

Supply	
PNC2 (board)	:24 Vdc ±15 % at 250 mA, or 18-0-18 Vac ±15 % (transformer centre tapped) 50 or 60 Hz 5 VA, or 18 Vac ±15 % (transformer isolated) 50 or 60 Hz 5 VA. (board must be earthed).
NBOX(B)/PNC2 /230	:230 Vac -15% +10%, 50 or 60 Hz, 7.5 VA.
/24	:24 Vac 50/60 Hz, or 24 Vdc ±15 % at 7.5 VA (not NBOXB)
Auxiliary supply out	:24 Vdc ±15%, 150 mA maximum
Fusing	:No fusing, protected by self-resetting devices
Battery Backup	:(NBOXB/PNC2/230). 230 Vac only. Maintains board operation for 20 minutes (typical) during mains failure
Lan transmission	:20 mA two wire current loop, opto-isolated, polarity independent receiver, balanced transmitter
Printer transmission	:RS232, EIA/TIA/232E, V28
Distance	
Printer	:15 m
Network	:Dependent on cable type, see table below:

Cable	1k2 baud	4k8 baud	9k6 baud	19k2 baud	No. of Wires
Belden 9182	1000 m	1000 m	1000 m	700 m	2
Belden 9207	1000 m	1000 m	1000 m	500 m	2
IQ system TP/1/1/22/HF/200 (Belden 8761)	1000 m	1000 m	700 m	350 m	2
IQ system TP/2/2/22/HF/200 (Belden 8723)	1000 m	1000 m	500 m	250 m	4

Baud Rate	
Lan	:Selectable by links 1k2, 4k8, 9k6, 19k2 baud-set to be same as other nodes on Lan.
Printer	:Selectable by links 1k2, 4k8, 9k6, 19k2 baud - set to be same as printer.
Lan address	:Selectable by board switches - set to be unique on network in range 1, 4 to 9, 11 to 119.

Mechanical

Dimensions	
PNC2 (board)	:151 x 160 x 35 mm (typical)
NBOX(B)/PNC2	:230 x 181 x 70 mm
Enclosure Material	
NBOX(B)	:Box, ABS
	:Terminal cover - clear Styrolux
Protection	
NBOX(B)	:IP30
Weight	
Board	:0.3 kg
NBOX	:1.0 kg
NBOXB	:1.1kg
Connectors	
Power	:2 part connector screw terminals 0.5 to 2.5 mm ² cross section area cables.
Lan/Aux	:2 part connector screw terminals 0.5 to 2.5 mm ² cross section area cables.
RS232/NBOX(B)	:25 Way, D type, Female.
RS232/Board	:10 Way, Molex, Male

Trend Control Systems Ltd reserves the right to revise this publication from time to time and make changes to the content hereof without obligation to notify any person of such revisions or changes.

Indicators

⚡ (Power)	:(green) On when supply is on.
! (Watchdog)	:(red) On if a processor or software fault.
DTRA	:(yellow) PNC2 busy to local Lan (Lan A), (normally flashes).
CTSA	:(yellow) Not used.
DTRB	:(yellow) PNC2 busy to printer (RS232 port), (normally flashes).
CTSB	:(yellow) Printer (RS232 port) busy to PNC2.
TX	:(yellow) Monitors current flow from PNC2 to IQ system Lan (Lan A).
RX	:(yellow) Monitors current flow to PNC2 from IQ system Lan (Lan A).
OK 	:(green) On if local Lan (Lan A) OK. Flashes if prohibited Lan address (0, 2, 3, >119) set on address switch.

Environmental

EMC	
emissions	:EN50081-1
immunity	:EN50082-2
Electrical safety	:EN61010
Ambient limits	
Storage	:-10 °C to +50 °C
Operating	:0 °C to 45 °C
Humidity	:0 to 95 %RH non-condensing
Flammability	
casing material	:Flame retardent, UL99/V0 Glow wire test, UL746A(3)

Version

Firmware	:v5.1
Board	:AM104178 v3

	P.O. Box 34, Horsham, West Sussex, RH12 2YF United Kingdom		Website www.trend-controls.com
	Telephone +44 (0)1403 211888	Fax (International) +44 (0)1403 210982	Fax (UK) +44 (0)1403 241608
E-mail trendinfo@novar.com	Registered office. Novar House 24 Queens Road Weybridge Surrey KT13 9UX Registered in England No 1664519		