

## IQView Touch Screen Display



### Description

The IQView is a touch screen display which provides a self configuring user interface to the IQ system. The IQView software presents the user with the familiar Windows operating environment. System access is provided by means of a navigator tree, enabling controller selection, and hence access to modules, graphs, alarms, and timezones.

The Mono version has a black and white screen with RS232, and the standard version has a colour screen with RS232, Ethernet, and IQ System current loop Lan.

There are surface or rear panel mounting variants with all units having a single relay output (e.g. for use with an alarm sounder).

### Features

- Ethernet, current loop Lan, RS232 connection options
- Surface or Rear panel mount versions
- 24 Vac, or 28 to 36 Vdc input power supply
- Touch screen
- Black and white or colour screen
- Autolearns network when connected
- Communicates with all controllers on local or remote networks (not autodialled networks)
- 8 users with configurable access rights plus full access user (Admin)
- Can connect directly to an IQ system controller
- View of inputs, outputs, directories, alarms, logs
- Adjustment of knobs, switches, time zones, time
- DHCP enabled

### Physical

#### Surface Mount Unit (/SM)

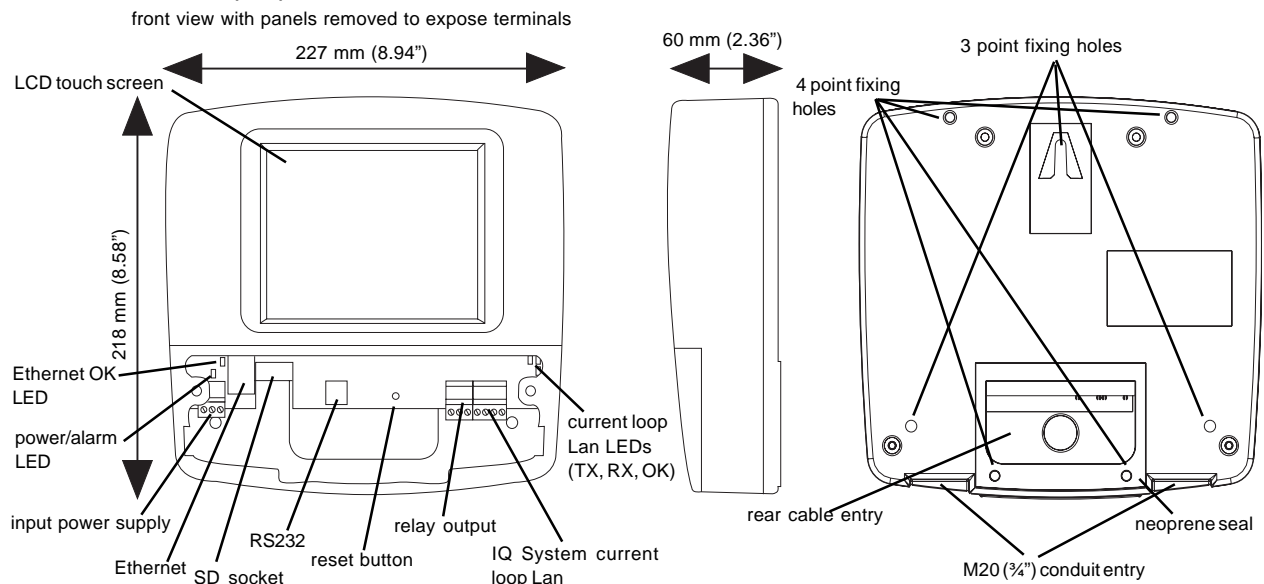

**Physical** (continued)

**Rear Panel Mount Unit (/RPM)**

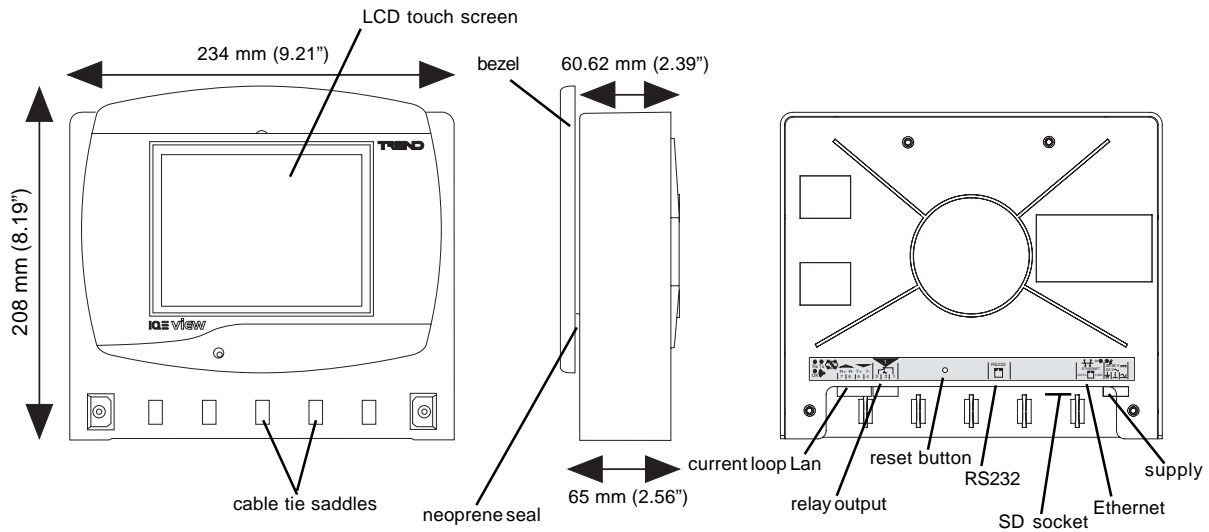

**IQVIEW/NDP ADAPTOR PLATE**

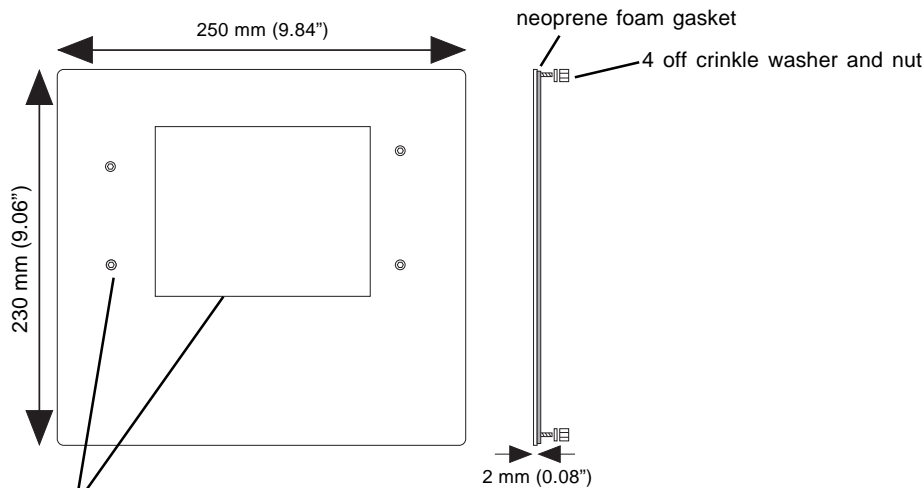

cutout and fixing holes for IQView/RPM

**FUNCTIONALITY**

The functionality of the IQView touch screen display can be split into system, hardware, and software sections:

**SYSTEM**

The IQView Mono version has an RS232 connection and the IQView (standard) version also has Ethernet and IQ system current loop Lan connections. The IQView is not designed for multi-site operation so there is not a setup which will access several sites. It cannot access autodialled sites (e.g using a TMN), and it cannot receive alarms from sites using autodialling or TCP/IP dial up.

**RS232 Connection**

The RS232 port on the IQView enables direct connection to the local supervisor port of IQ1xx, IQ2xx series or IQ3 controllers. For IQ1xx and IQ21x controllers this will give access only to that controller, but all other IQ2xx and IQ3 controllers have a local supervisor CNC (sCNC) which can provide access to the IQ system network.

The RS232 port also enables connection to the IQ system current loop Lan through a CNC (e.g. NBOX/CNC2). The IQView Site Connection is set to Connect to CNC/RS-232, and the RS232 baud rate should be set to match that of the controller's or CNC's RS232 port (normally 9k6).

The signal connection to IQ2xx, IQ3, and some IQ1xx controllers requires an RJ11 to RJ11 adapter cable with a twist (CABLE/EJ105650 - supplied with IQView Mono only).

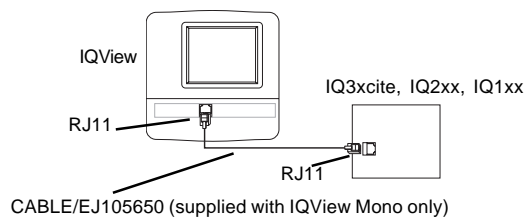

### RS232 Connection

The signal connection to CNC's or IQ1xx controllers with a 25 way socket requires an RJ11 to 25 Way D type male adapter cable (CABLE/EJ105651).

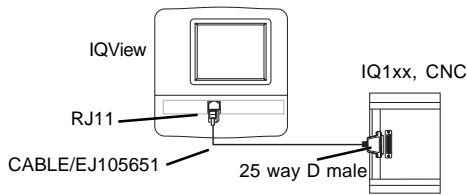

Some IQ1xx's have a 5 way in-line local supervisor port connector which can be connected using the CABLE/EJ105651 in conjunction with the 25 way socket to 5 in-line socket adapter cable, CABLE/78-1172.

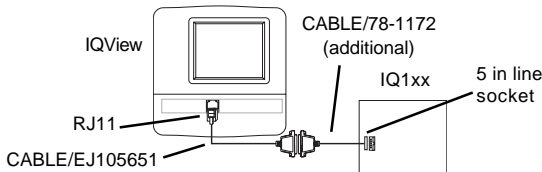

IQ Controllers with a local supervisor CNC have the sCNC address set by default to zero which gives the IQView access to the local controller only. In this configuration the local controller's alarm reporting address should be set to 2 (local direct connected supervisor). In order for the IQView to access the network, the sCNC address (**ndp port addr** for IQ241/242, 251, **supervisor port addr** for IQ204, 22x, 246, 250) should be changed to a valid network address, and the local controller's alarm reporting address set to the same address for its alarms to be reported to the IQView.

The diagram below shows an IQView (A) connected to an IQ2xx with its sCNC set up. This gives the IQView access to the local Lan and across the internetwork to the other Lans. The IQView takes the network address set on the sCNC and the Lan number of the IQ's local Lan.

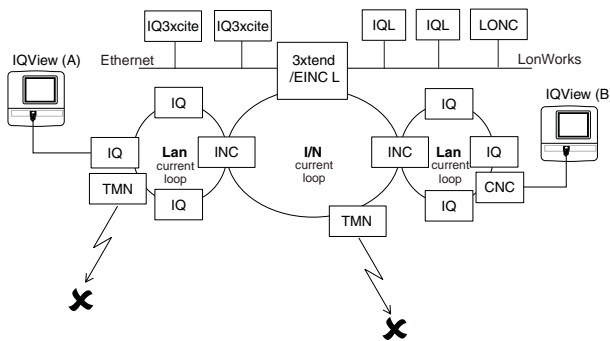

A second IQ View (B) is connected to the network through a CNC. This IQView has similar access to the previous one and takes the address set up on the CNC's address switches and the Lan number of the CNC's local Lan.

The 3xtend/EINC L is set for internetwork extension mode, and gives access to the IQ3s on Ethernet and IQLs and LONC on LonWorks. The IQView's can neither access any autodialled sites (e.g. using a TMN) nor receive alarms from them.

The 3xtend/EINC L may be replaced with a combination of EINC and LINC. The 3xtend/EINC L differs from the EINC in that it can operate in an automatic IP addressing environment (e.g. with DHCP) and has a LonWorks bus connection enabling the extension of the internetwork over Lonworks, and communication with IQLs.

### IQ System Current Loop Lan Connection

This enables connection of the IQView directly to the current loop Lan i.e. the IQView has an internal CNC. The IQView Site Connection is set to Connect as Device/Current Loop Lan the internal CNC address is set to a valid network address, and the baud rate is set to match the Lan baud rate.

The diagram below shows an IQView connected to the network through its current loop Lan connection. This connection gives the same range of access to the network as that given to the IQView with RS232 connection described previously.

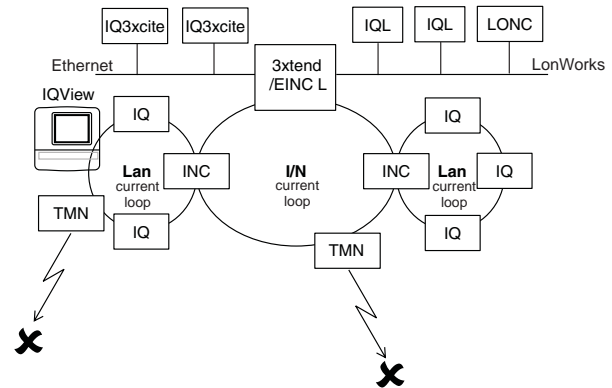

### Ethernet Connection

The IQView can connect to an Ethernet hub using a standard Ethernet cable.

*Note that Ethernet cable and plugs are available from your IQ system supplier.*

It can also connect directly to the Ethernet port of an IQ3 controller using a standard Ethernet cable (Cat 5e unshielded, UTP, or shielded, FTP, with RJ45 plugs unshielded or shielded as appropriate) with a crossover adaptor (XCITE/XA/5, pack of 5 adaptors).

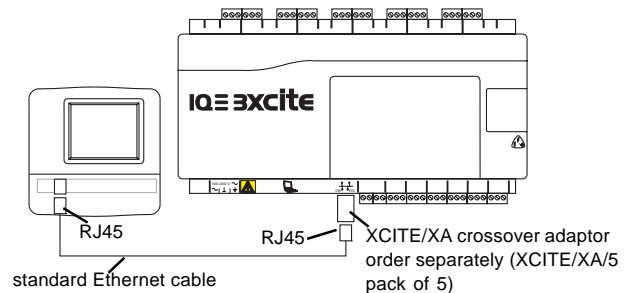

The IQView must use an Ethernet virtual CNC (vCNC) to communicate with IQ System devices over Ethernet. The IQView can use its own internal vCNC (Connect as Device/Ethernet Lan), or it can connect to a vCNC in either a 3xtend/EINC L, or an IQ3x (Connect to CNC/Ethernet vCNC). The IQView makes a permanent connection to the virtual CNC and this also enables controllers to send their alarms to the IQView through the vCNC. The time taken for the system to be available for mapping will depend on the type of Ethernet connection. If Connected to CNC/Ethernet vCNC, the mapping should be instantaneous (if the system is stable i.e. it has been powered for some time and the nodes are correctly configured). If Connect as Device/Ethernet Lan then the time taken can vary from <30s to <130s depending on its IP address and whether the network crosses a router.

The diagram below shows the IQView connected to Ethernet.

**Ethernet Connection (continued)**

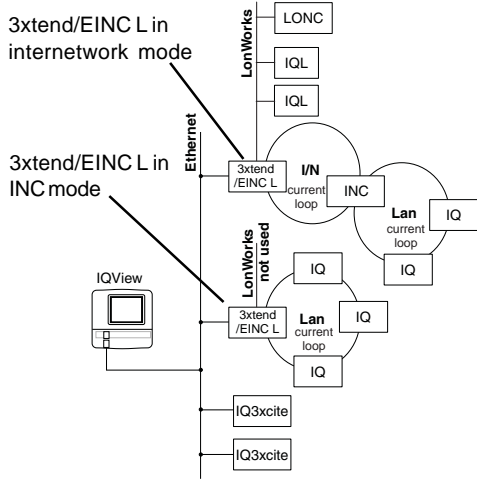

The Ethernet network is also connected to IQ3s and 3xtend/EINC Ls.

It can access the IQ3s, and the IQ Lan connected by a 3xtend/EINC L in Ethernet INC mode. It can also connect through the 3xtend/EINC L in Ethernet internetwork mode to another IQ Lan and to some IQLs on LonWorks.

To use an Ethernet connection, the IQView must have its own IP address, its subnet mask, and the default gateway (router) IP address defined. By default the IQView is set to receive these Ethernet settings automatically from a DHCP server (Dynamic Host Configuration Protocol), but if this option is deselected, then the settings must be set up manually.

If set up to Connect as Device/Ethernet Lan, then it must have its own Lan number and network address set up as well as having the UDP port set to match the UDP used by the rest of the IQ system.

If set up to Connect to CNC/Ethernet vCNC, then it must have the IP address of the 3xtend/EINC L or IQ3, and the port number which defines the virtual CNC within the 3xtend/EINC L or IQ3 (the IP address and virtual CNC port number are configured in either the 3xtend/EINC L or IQ3 and must be set to be the same in the IQView). In this case the IQView will take the Lan number of the 3xtend/EINC L's or IQ3's Lan, and the network address of the virtual CNC.

**Configuring IQView to Cross Routers**

This is done by setting up the IQView's Default Router IP address (for a router on its own subnet) and a Remote Device's IP address, and subnet mask (for a IQ3, 3xtend/EINC L, or IQView on the other side of the router). The remote device's details can only be set up using IPTool

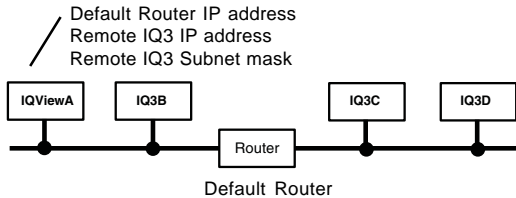

In the above diagram, if IQview A is the lowest IP address on its segment (cross router master), it should be configured with the default router IP address and the remote IQ3's (IQ3C's) IP address and subnet mask. It will now send a message to IQ3C's subnet through the default router. IQ3C will then reply and the IQViewA will construct the internetwork between the two IQ3s. If IQ3C is the cross-router master on its subnet, it will also have to be set up to create an internetwork with IQViewA by entering its default router IP address and IQViewA's IP address and subnet mask.

If IQ3C's power fails then IQView A will not be able to create the network with it; to overcome this problem IQ3D's details should also be entered in the network module of IQViewA so that it can connect to IQ3D if IQ3C is switched off.

In general with multiple routers, the details of at least one IQ3 from every subnet must be set up in the cross router master. The remote cross router masters will need similar details to be set up but these must include the details of the original device.

To reduce risk of losing communications due to one device's power fail, the two devices with the lowest IP addresses from each subnet should be set up in the two devices with the lowest IP addresses on the local subnet.

Up to 20 devices' details may be entered in the network module.

Because IP addresses may not be fixed (see Automatic IP Addressing - below) it may not be possible to specify which controllers have the lowest IP addresses, so the details should be set up in every device on the subnet, so that any device may be able to become the cross-router master. If Automatic IP Addressing is being used, the remote devices will be identified by host names rather than IP addresses.

**It is recommended that the details of two devices (either IQViews, 3xtend/EINC Ls or IQ3s) in the network from each subnet the other side of a router should be set up in every device in the network (either IQViews, 3xtend/EINC Ls or IQ3s) on the local subnet.** For increased reliability, details of additional devices should also be set up.

**Automatic IP Addressing**

The IQView is able to operate in a system where the IP addresses are automatically allocated by a DHCP (Dynamic Host Configuration Protocol) server (i.e. the IP addresses are not fixed).

**Obtain an IP address automatically:** The IP Addressing is set to 'Obtain IP address via DHCP' by default and can be changed to 'Specify an IP address' for traditional manual entry with a fixed IP address.

**DHCP Operation:** If set to 'Obtain IP address via DHCP', when the IQView powers up it will inform the DHCP server which can then provide it with:

- IP Address
- Subnet Mask
- Router 1 (default router)
- WINS Servers (1 to 2)
- DNS Servers (1 to 2)

**Link/Local Operation:** If the IQView is in automatic IP addressing mode and the DHCP server fails to respond, the IQView will enter **link/local mode** where it will negotiate its IP address with the other devices on its Ethernet segment. There may be some time delay between DHCP server failure and the IQView entering link/local mode as it will only prompt the DHCP server after its lease has expired which may be a long time. The first IQView or IQ3 to go into link/local will cause the others on its segment to go into link/local.

In link/local mode the IP addresses start at 169.254.0.0, the subnet mask will be set to its default (255.255.0.0), and the Router 1, WINS servers, and DNS servers will remain at their last settings. Any devices wanting to communicate with an IQView or IQ3 in link/local using IP addressing must be on the subnet so defined.

**Summary of IP Addressing Modes**

IP Addressing Mode	IP addressing set up by	
Obtain IP address via DHCP	<b>DHCP</b>	IP address may vary
	<b>Link/local</b>	
Specify an IP address	<b>Manual</b>	IP address fixed

**Hostname:** Because the IP address is no longer fixed in automatic IP addressing mode, the IQView has an additional addressing parameter, the Device name (host name), which is fixed. When the IQView powers up it sends its host name to a WINS (Windows Internet Naming Service) server. If a device wishes to communicate with the IQView it will send the IQView's host name to the WINS server which will return the associated IP address.

**Ethernet Connection** (continued)

**Automatic IP Addressing**

If a WINS server does not exist, the host name can be used over the local segment only (i.e. not across routers).

The host name can also be used to communicate with the IQView if 'Specify an IP address' is selected. This provides a user-friendly way of identifying the controller rather than remembering its IP address.

**Default Host Name:** If the host name has not been set up, the IQView will power up with a default host name which is a function of its MAC address ('Trend' plus the last six digits of the MAC address e.g. TREND\_00\_14\_D0). The default host name will always be operational (as well as its Hostname if it has been set up).

**Fixing the IQView's Address on a DHCP controlled System:**

It is possible for the IQView to operate in a DHCP regime with a fixed IP address by setting up the DHCP server so that it always gives that particular IQView the same IP address. An alternative is to set the IQView to 'Specify an IP address', and set its IP address outside the range of the DHCP server.

**Crossing Routers if DHCP is operating:** In the DHCP regime, if the internetwork is to cross a router(s), the Remote Devices (1 to 20) IP addresses should be set up as host names. This will enable the IP addresses to be obtained from the WINS servers.

**If the network is to cross a router, the details of two devices in the network from each subnet the other side of a router should be set up in every device in the network on the local subnet.** For increased reliability, details of additional devices should also be set up.

*Note that If any communication using a hostname crosses a router(s), then a WINS server address must be set up.*

**Link/local Default Operation:** IQViews, IQ3s, and 3xtend/EINC Ls are set to automatic IP addressing by default. If a group of these devices are connected together on an Ethernet segment (without DHCP, WINS servers) they will power up in link/local and auto-negotiate their IP addresses. If they have been set up with device addresses and Lan numbers they will construct a Trend IQ system network. A supervisor or system tool running on a PC on the same segment will be able to communicate with them using host names (if the PC is set up for auto-addressing). Such a system cannot form a network across a router.

*Note that it is recommended that Link/local only be used as normal operation on a single segment system, (not across a router). Also note that any other device communicating with these devices (e.g. a supervisor PC) must also be in link/local.*

**Servers:** If the IQView's IP address settings are to be supplied by a DHCP server, the server must be installed on the same segment as the IQView.

If host names are being used for IP addressing across a router, then a WINS server must be installed on the system and the DHCP server must be capable of downloading the WINS server address.

**HARDWARE**

**Box:** There are two mechanical versions of IQView: the surface mount unit, and the rear panel mount unit.

The surface mount version (/SM) has a snap on cover which can be levered off to reveal the labelled terminal cover. This can be unscrewed to expose the terminals, LEDs, and pushbutton.

The Power/Alarm LED (blue) can be seen externally with the covers in place. There are two M20 (or 3/4") conduit holes fitted with plastic bungs in the base of the box for cable entry and a rear rectangular aperture for rear cable entry surrounded by a neoprene seal. The unit is either three point mounting (e.g. for mounting on a wall) or 4 point mounting (e.g. for mounting on a panel). The 3 hole mounting method uses M4, 5, 6 or No. 10 or 12 screws; a ramped keyhole slot in the top back centre of the unit slips over a screw head, and as the unit is lowered the unit clamps onto the wall creating a seal around the rear aperture; the two lower right and left mounting holes can be used to spot their mounting centres. The 4 hole mounting method uses 4 off M4 x 16 mm screws; this gives a maximum panel thickness of 10 mm (0.39"). The template provided is only for use for 4 hole mounting.

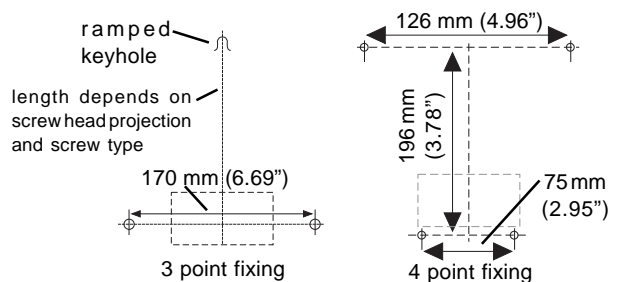

The rear panel mount version (/RPM) is mounted behind a rectangular aperture in the panel using the 4 countersunk cross headed screws (M4 x 12 mm) provided, and a plastic infill is clipped over the front bezel to hide the screw heads.

*Note: Only use screws of the correct size.*

The maximum panel width is 6 mm (0.24"). A neoprene seal is fitted around the screen to make the screen watertight from the panel front. The cables enter the IQView through the bottom of the unit, and there are 5 saddle piercings in the unit to facilitate securing the cables with cable ties. A mounting template is provided.

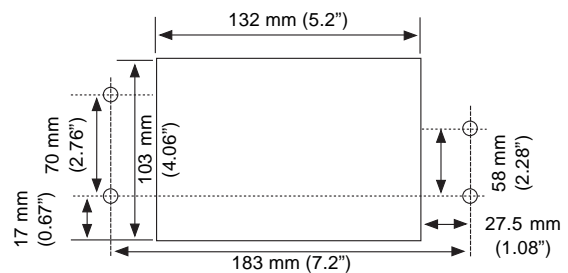

**WARNING:** Note that, other than removing the front covers on the surface mount version (/SM), no attempt should be made to open the unit. Failure to comply may cause damage to the unit.

**HARDWARE** (continued)

**Adaptor Plate:** An adaptor plate (IQVIEW/NDP ADAPTOR PLATE) is available as an accessory to facilitate the replacement of a panel mounted NDP with an IQView.../RPM.

Mounting the adaptor plate on the panel requires a square cutout and 4 holes; this is facilitated by the template provided with the adapter plate. The adaptor plate is mounted on the panel by 4 studs, and the 4 crinkle washers and nuts provided. The plate has a neoprene gasket which maintains the IP54 rating.

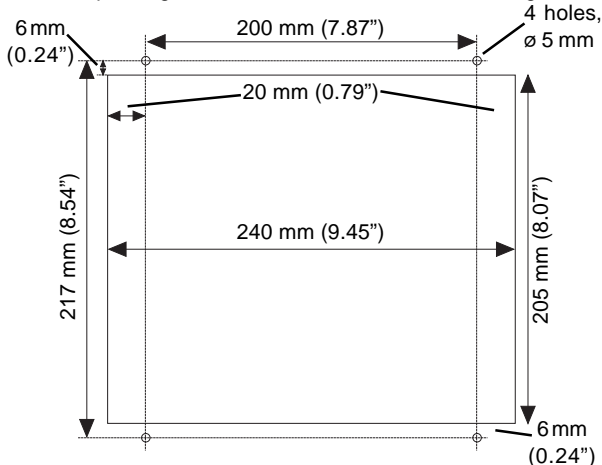

It has a finish to match the standard ENCLS cabinets, but can be sprayed by the installer to match the panel if required.

**Power:** The unit requires 24 Vac, 50/60 Hz, or 28 to 36 Vdc. The maximum consumption is 24 VA. This power level cannot be provided from an IQ controller's auxiliary supply output, so a separate supply is required.

Note that the 'neutral' terminal (⊥) of the 24 Vac input power supply is internally connected to the IQView's earth (ground) terminal. A 230 V/24 Vac, 24 VA, transformer is available (ACC/24VAC). This is a sealed unit with two mounting lugs; it has an isolated 24 Vac output and an additional earth (ground) lead connected through from its input power supply earth (ground) for earthing (grounding) the IQView.

A general purpose 24 Vac transformer may be used to supply the IQView, but if one side of its output is earthed (grounded), this side must be connected to the IQView's 'neutral' (⊥) terminal. The PSR/230/24-2.5 DIN rail mounting DC power supply may be used to supply the IQView, but its output voltage level must be adjusted for maximum volts (28 Vdc).

The IQView must be earthed (through its input power supply earth (ground) terminal)

**Fusing:** The input supply is protected by a 6.3 A fast-blow fuse; this protects the IQView board from drawing excessive current from the supply. If it blows the unit should be returned to the supplier for repair.

**Current Loop Network:** (not IQView Mono). The network terminals facilitate connection of 2 wire cables. The standard IQ system current loop features are included (TX, RX, and network OK, 📶, indicators, bypass relay, and network alarm generation).

The IQView's network address and baud rate on the current loop Lan are set in the application software. The address must be in the range 1, 4 to 9, 11 to 119, and must be unique on the local Lan. The baud rate can be set in the range 1k2, 4k8, 9k6, 19k2, and must match the other nodes on the Lan.

**Relay output:** The IQView has a single changeover relay output. If the relay is enabled, it energises when an alarm occurs. It is disabled by default, but can be enabled using the software. Acknowledging the alarm will de-energise the relay. The relay can be used to drive an external alarm annunciator (visual or audible).

**Indicators:** The following indicators can be seen after removing the terminal covers:

**Power/Alarm:** (blue) This LED is normally ON to indicate that the input power supply is connected. It will flash if there is an alarm present. If OFF it indicates a supply failure.

**Ethernet OK:** (green) ON if the IQView has successfully communicated with at least one IQ system device on Ethernet (e.g. IQ3, EINC). ON if network on Ethernet has been constructed. OFF if IQView is alone.

**Ethernet LINK:** (green) ON if the IQView has a good Ethernet connection. If OFF it indicates a faulty Ethernet connection

**Ethernet DATA:** (yellow) Flashes when a package of data is being received from the Ethernet

**TX:** (yellow) ON if current is flowing from network transmitter

**RX:** (yellow) ON if current is entering the network receiver

**OK (📶):** (green) ON if network is operating

The Power/Alarm LED is visible through the front of the surface mount unit only. On the surface mount unit all other LEDs are visible after removing the covers; on the rear panel mount unit the LEDs can be checked using a mirror.

**Sounder:** By default the audible sounder is enabled so that it sounds when the touch screen is tapped, or when an alarm occurs. It can be disabled using the application software. Acknowledging the alarm will switch off the audible alarm.

**Battery:** The IQView does not require a battery. User configuration data is stored in non-volatile memory (Flash). A supercap is used to maintain the real time clock (time and date); in the event of power failure this will support the clock for a minimum of 24 hours (at 20 °C, 68 °F). Note that the supercap needs about 2 minutes to reach full charge after power is applied. The alarm list and any other data (e.g. site navigator tree) is lost on power failure.

**Connectors:** Two part connectors are used throughout to facilitate installation.

The Ethernet and RS232 ports use RJ45 and RJ11 sockets respectively. The input power supply, relay output, and network connections use two part screw terminals.

**Display:** The IQView Mono version has a black and white display, and the IQView (standard) version has a colour (256 colours) display. Both displays are LCD 320 x 240 pixels (¼ VGA) STN with touch screen. The backlight is electroluminescent (CCFL) with autodim. The autodim function enables the screen brightness to be dropped to ½ brightness after a time defined in the application (1, 2, or 5 minutes). The screen has a digital contrast facility enabling it to be set by a slider function within the software.

*Note that the screen should only be tapped using a finger, no sharp objects (e.g. screwdriver) or pointers should be used. Failure to comply may damage the unit.*

*Note that the screen should be cleaned regularly to remove dust and grease by wiping gently with a soft cloth such as that used for cleaning the lenses of spectacles.*

**SD Card:** The IQView has an SD card socket which will take an SD/MMC card (Secure digital/Multimedia card). This can be used to backup and restore the user configuration data. The data can be written to the card, and the card may be removed and stored in a safe location as a backup or to transport the configuration from one IQView to another.

The SD card is also used to upgrade the firmware. Firmware upgrades can also be supplied as a file along with a utility to write it onto an SD card from a PC; an SD Card Writer will be required for this operation. The programmed SD card should be plugged into the IQView. The reset button should be pressed and held own, and soft reset should be selected from the screen. The firmware will then be upgraded (see IQView Upgrade information sheet, TG200758).

## SOFTWARE

The IQView application runs within a Windows CE.NET operating system. Full details are given in the IQView Manual, TE200719. The software is field upgradeable.

### Power Up:

When an IQView powers up for the first time it prompts the user to select the language, then to set up the site name and communications' connection.

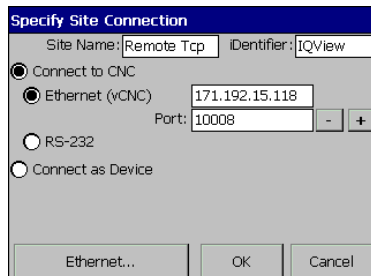

This enables four different types of connection to be configured: either **Connect to CNC** and

either **Ethernet vCNC**: connects to Ethernet vCNC in either EINC or IQ3. Then set up IP address of IQ3/ EINC and port number of vCNC

or **RS232**: connects to CNC module or IQ controller's local supervisor port. Then set up baud rate.

or **Connect as Device** and

either **Current loop Lan**: connects as device on current loop Lan using IQView's own internal CNC. Then set up Lan number, network address, and baud rate

or **Ethernet Lan**: connects as device on Ethernet Lan using IQViews internal Ethernet vCNC. Then set up Lan number, network address, and UDP port.

If either of the Ethernet connections are set up, the IQView's own IP address, Subnet mask, and Default gateway must also be set up. By default the IQView is set for automatic IP Addressing (e.g these Ethernet settings are received from a DHCP server), but if this option is deselected, then the settings must be set up manually; this can be done using IPTool (v1.1 or greater) if preferred.

Automatic addressing also requires set up of the IQView's device name (host name) and a WINS server address (if the internetwork crosses a router); the WINS server address setting would also be received from the DHCP server.

IQView will then try and learn the internetwork and ask the user if it should learn the Lans. (If not answered it will learn them anyway.) It will then present the Navigator display (see later) enabling the user to start accessing the network



On a subsequent power up it will retain site and connection information and start learning the internetwork straight away. If Users are enabled, it will show the log in display.

This enables the user to select his name from a drop down list, and to enter his password. This will give him certain access and adjustment rights; specified display objects can be hidden from him. After successful entry the IQView will present the navigator display.

### Configuration

The IQView can have the following items configured: (The full description of configuring the IQView is covered in the IQView Manual TE200719.)

**IQView display:** Back light timeout, Sound when touching screen on/off, Contrast adjust (the contrast should be adjusted to suit the environment/viewing angle), recalibrate the touch screen

**Time:** Set up IQView's time and date. Used to time/date stamp alarm acknowledgments, and for synchronising controllers (if required). The IQView can also be set up to receive system timemaster time synchronisation messages.

**Ethernet Settings:** The IQView's IP address, subnet mask and Default gateway's (router's) IP address (required if the connection to the system is through Ethernet). WINS and DNS servers' IP addresses. Device name (host name) required if automatic IP addressing set up.

**Connection:** Site name, and type of connection as described above

**Users:** Set up user's with passwords and PINs and define what they are able to access or change: IQView, Site, and Lan menu icons in the toolbar, full navigator tree displayed or certain Lans and outstations hidden, display and directories, time, timezones, alarms in IQ/IQL controllers, modules (sensors, switches, knobs, digital inputs, drivers), add/remove items from navigator tree, enter PIN, acknowledge or delete alarms, set graph display options. By default the IQView has no users set up (i.e. no security); setting up a user will also automatically set up an Admin user with full access rights.

**Alarms:** The types of alarms that are added to the received alarm display. Unselected received alarms are rejected. Types are critical, general, module, network, dialler, or access. The alarm actions can also be specified (sound internal buzzer, flash screen, flash LED, energise relay output).

**Language:** This enables the text language, date, time and decimal separator formats to be set to other languages including English (UK), English (US), German, French, Spanish, Swedish, Danish, Norwegian, Finnish, Geek, Simplified Chinese, Romanian, and Russian.

The IQView configuration options can be selected from a dropdown menu produced by tapping the IQView menu icon, , shown in the standard display below.

**SOFTWARE** (continued)





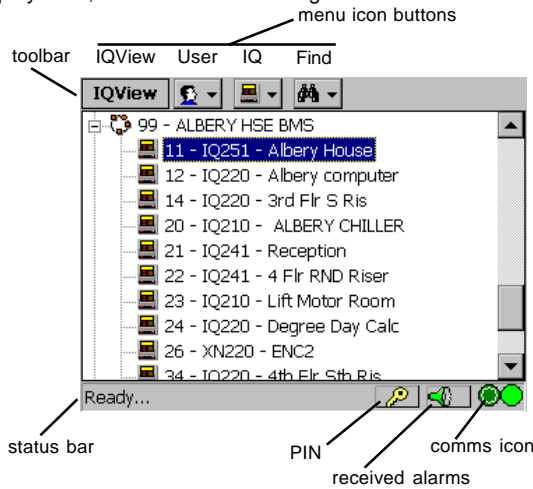

**Standard Display:**

The standard display consists of a toolbar along the top, a central display area, and a status bar along the bottom.



The toolbar contains menu icon buttons which change according to the context of the display. Touching a menu icon which includes a downward arrow (e.g. ) produces a drop down list of options.









The status bar shows the current status of the display (e.g. ready) and the PIN, received alarms, and communications icons.

-  **PIN:** Enables the PIN to be changed (e.g. to match the controller's PIN)
-  **Alarms:** Gives access to the received alarms list. The flashing red icon indicates there are unacknowledged alarms in the list. The green icon indicates all the alarms have been acknowledged.
-  **Comms:** Indicates communications status.
  -  (two dark green circles)  
Indicates that communications are OK
  -  (one dark and one light red circle)  
Indicates a comms error.
  -  (one dark and one light green circle).  
This icon is shown after the icon is tapped and indicates that a comms check is in progress (it should last for for 1 sec).

**Navigator Display:**

An example of the navigator display is shown in the standard display section above.

The system tree is shown on the left. The house icon at the top of the tree (not shown in the example) represents the site and has the site name adjacent to it. The vertical line below the house has the Lans branching from it. The Lans act like directories in Windows Explorer, and Lans containing IQ/IQL controllers will have an adjacent plus sign. Clicking on the plus sign expands the Lan and shows all the controllers with specific icons to represent the controller types. The Lan now has a minus sign enabling it to be contracted back to the Lan icon. The following site, Lan, and outstation icons are shown:

-  Site
-  Broken Lan:
-  Empty Lan: This Lan contains no IQ/IQL controllers.
-  IQ/IQL Lan: This Lan contains IQ/IQL controllers. An adjacent plus sign indicates it can be expanded
-  IQ1xx controller
-  IQ2xx controller
-  IQ3 controller
-  IQL controller

When the site icon is selected a similar Site menu icon button appears in the toolbar enabling the Site connection to be re-initialised, or Lans to be learnt.

The system timemaster can be found by a single item selection; if found, the timemaster controller will be highlighted. The controller can then be selected and its time synchronised to that of the IQView.

When a Lan icon is selected, a similar Lan menu icon button appears in the toolbar enabling the Lan to be learnt, or non-controller devices to be listed.

When a controller icon is selected a similar controller menu icon button appears in the toolbar enabling selection of the following:

**Directories:** (Not IQ1xx or IQ2xx pre v2) Select display and directory modules, enabling monitoring and adjustment of specific items programmed into the controller

**Timezones:** (Not IQL) Select the time zones, enabling monitoring and adjustment of occupation times, identification of timemaster, and synchronisation of the outstation time. For IQ1xx, 2xx, the IQView can access every week and this week, and for IQ3, the IQView can access every week and exceptions.

**IQ Alarms:** (Not IQL) View the alarms in the controller, either current, or historical.

**Modules:** Select the page of modules required, either Sensors, Knobs, Digital inputs, Drivers, or Switches. This enables monitor and adjustment of the individual module

The other menu icon buttons are IQView, User, and Find

 This icon enables the user to configure the IQView, (users, alarms, connection, display, Ethernet settings, date and time), use SD card (import/export user data or unit settings e.g. site connection, alarms, display, language etc), Restart (full soft reset), Information (Serial number, software versions, product variant, duration, and diagnostics).

 This icon enables a user to log on, or log off, or change his password.

 This icon enables all Lans to be expanded or contracted, a particular IQ to be located, an IQ to be added, or an IQ/Lan to be removed from the tree. The system timemaster can be located.

**Directories Display:**

The Directories display shows the controller's display and directory modules. These enable the controller's sensors, digital inputs, knobs, switches, drivers, and time zones to be displayed on a number of pages in a hierarchical manner.

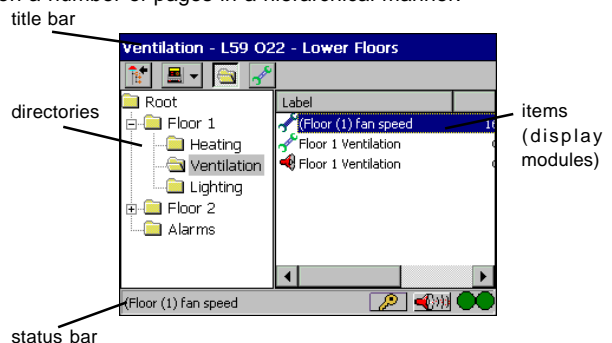

The directories display has a title bar which shows the currently selected directory module with the IQ/IQL address and identifier (ID label).

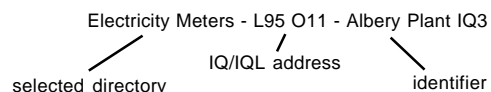

**SOFTWARE** (continued)



The status bar shows the label of the currently selected item (display module).



The left side of the central display area shows the directory modules in a hierarchical tree structure, and the right side shows the items (display modules). The item display has columns for icon, label, value, units, and item code (e.g. D12, driver 12). Both sides of the screen have horizontal and vertical scroll bars.



The  icon in the toolbar toggles the display of the directory tree on and off, so only items may be shown.



The  icon in the toolbar returns the user to the navigator display described above.



The following icons prefix the item lines and appear as buttons in the toolbar.

 This indicates that the knob or switch can be adjusted. The  icon is shown if the adjustment cannot be changed due to a low level PIN. Pressing the  button on the toolbar produces a popup display which enables the adjustment to be made.

 This indicates that the sensor is being logged in the controller. Pressing the  button on the toolbar produces a popup display which allows the required log to be selected (logging period, number of points), whether a compact or full precision graph is required, and whether the display should be based on the IQ/IQL time or the time in the IQView.

 This indicates a time zone (not available on IQL). Pressing the  button on the toolbar produces a popup timezone display which shows the times for each day of the week and enables times to be changed as shown below.

 This indicates that the item is in alarm. Pressing the  button on the toolbar produces a popup display which shows the alarm details.

 This indicates a driver or digital input. Pressing the  button on the toolbar produces a popup display which shows the driver or digital input details (e.g. for digital drivers and digital inputs this includes number of starts and hours run, for analogue drivers it includes range and offset).

 This indicates that a driver has been disabled

 This indicates that a driver has been overridden by a software tool or supervisor

 This indicates that a driver has been forced on using a hand/off/auto switch

 This indicates that a driver has been forced off using a hand/off/auto switch

**Graph Display**

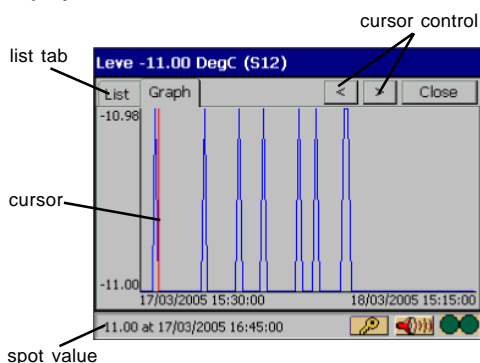

The graph display shows the times of the earliest and last sample on the time axis, and the maximum and minimum values on the y axis. The title bar gives the label, current value, units and item code. The vertical red line acts as a cursor and the < and > buttons act as the cursor control. The cursor can also be controlled by tapping the screen at the required position. The spot value is shown on the status rail at the bottom of the display. Selecting the List tab produces a list of each sample in the log with columns for sample number, date, time, and value.

**Timezones Display** (not IQL)



Label	Status	Item
C2 Ahu Plant	On	Z1
C3 Ahu Plant	On	Z2
Loading Bay Heating	On	Z3

The timezones display show the timezones in the controller and their current state. It also shows whether the controller is a timemaster, the controller time, and the IQView time and enables the controller time to be synchronised from the IQView time.

IQ1xx, 2xx controllers also have Zone 0, Special Days/Calendars, shown. Selecting this enables the special days and calendars (start/stop dates, and use-onceonly/every year/unused) to be set up which causes the time zones to operate exceptional working times (e.g. holidays)





Selecting a timezone and selecting the  menu icon button causes the weeks display to be shown with the 'every week' tab displayed.

The timezone display depends on the type of controller: For all controllers the first page displayed is every week (standard week in IQ1xx, 2xx). In IQ1xx, 2xx the second tabbed page selects current week, while in IQ3 the second tabbed page selects exceptions (e.g. holidays)

The following icon appears adjacent to the days of the week:  This icon indicates that the times can be changed. This icon  indicates that times cannot be changed due to a low level PIN.

**SOFTWARE** (continued)



The following buttons in the toolbar assist with editing:

-  This button enables the selected day's times to be copied to clipboard
-  This button enables the day's times in the clipboard to be pasted into the selected day
-  This button produces a dialogue box which enables time periods to be added or deleted, and the times to be changed.
-  This button is used to add exceptions
-  This button is used to delete exceptions

**IQ Alarms**

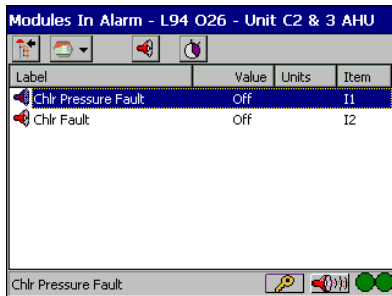
Selecting IQ alarms gives a further choice of either current or historic (IQ only) alarms.



The current IQ alarms display shows all the items in alarm. This display is similar to the directories item display (display modules) except that all the items are in alarm, so all the item lines have the  icon as a prefix. Selecting the  button in the tool bar will give alarm details.

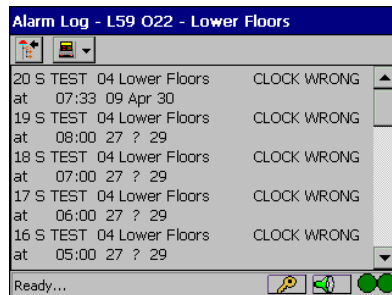

The historic alarms display (not IQL) gives a view of the controller alarm log (alarm history buffer). This shows the full alarm message for each alarm that has been logged.

e.g.

log number 2  
 item \_\_\_\_\_  
 label S7 Test Sensor, Outside limits cleared, cleared  
 time and date 13.30 21/04/2004 alarm cleared  
 or occurred

**Module Displays**

The module displays are of either Sensors, Knobs, Digital inputs, Drivers, or Switches. They are all similar to the directories item display (display modules) except that the display is all one type of module. The same icons and buttons apply as appropriate.

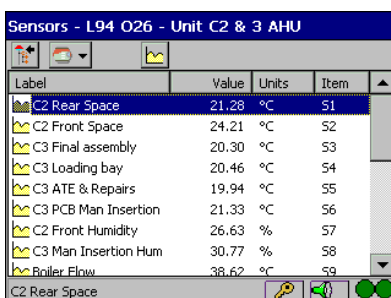



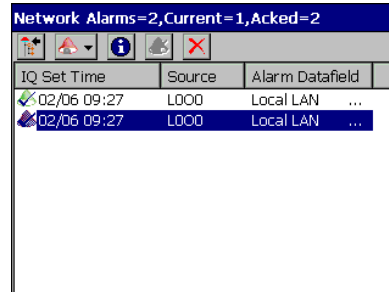

**Received Alarms**

This is a list of the 100 most recent alarms received from the system by the IQView. It provides the ability to view alarm details, and to acknowledge the alarm. When a cleared alarm occurs following an occurred alarm the occurred alarm will be deleted from the list and the time the alarm occurred will be added to the cleared alarm details.







The display has three columns, time received, source, and alarm datafield. Clicking at the top of a column will sort the list alphanumerically for that column. The alarm datafield column will sort according to the alarm codes (e.g. HELP)

The display has the following icons prefixing the alarms:

-  An alarm that has occurred
-  An occurred alarm that has been acknowledged
-  A cleared alarm
-  A cleared alarm that has been acknowledged

The following menu icon buttons are in the toolbar:

-  This button produces the drop down alarm menu which gives the ability to turn alarm actions on, acknowledge all alarms, or delete all alarms, all acknowledged alarms, or all cleared alarms
-  This button gives the alarm details
-  or  These buttons enable the selected occurred or cleared alarm, respectively, to be acknowledged
-  This button deletes the selected alarm from the list

When an alarm is received the IQView will perform its alarm actions as configured (sound internal buzzer, flash screen, flash LED, energise relay output). When the received alarm display is accessed the alarm actions cease. When the alarm display is closed the alarm actions resume if any unacknowledged alarms exist, or if the alarm actions have been turned on from the alarm menu.

**SOFTWARE** (continued)

**Users**

The individual users are activated from the 'Manager Users' display. Once selected a user may be edited.

Selecting 'MORE' gives access to more user details as shown below:

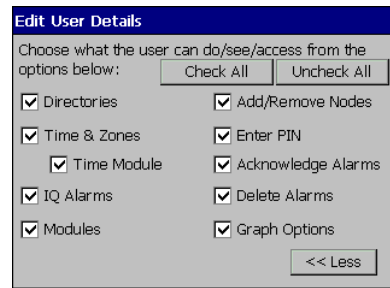
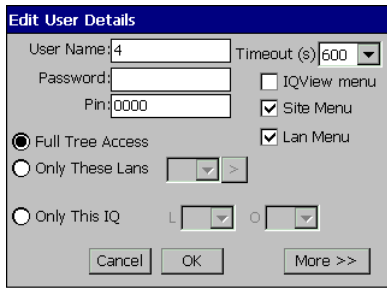

This enables the user name, timeout, password, and PIN to be edited and the user level of access defined. The level of access consists of Full tree access, only certain Lans, or only a single IQ. Also the IQView menu, Site Menu icon option, or Lan menu icon option can be individually selected. The ability to restrict the user to certain Lans can be useful for a multi-tenanted building.

**Identification**

The IQView identifies itself to w comms as 'IQView'. Text comms R(d,c) give address module identifier and full version (IQView, Iss 1.20 'mmm dd yyyy'). The full list of address module and time module text comms are given in the manual.

**DISPOSAL**

COSHH (Control of Substances Hazardous to Health - UK Government Regulations 2002) ASSESSMENT FOR DISPOSAL OF DISPLAY. No parts affected.

**RECYCLING.**

All plastic and metal parts are recyclable. The printed circuit board may be sent to any PCB recovery contractor to recover some of the components for any metals such as gold and silver.

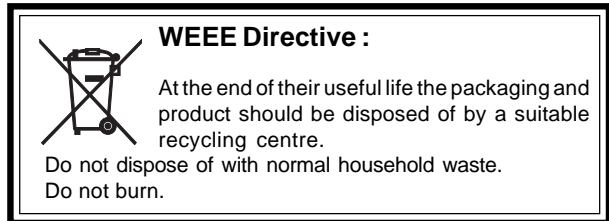

**COMPATIBILITY**

The IQView will show any Lan nodes in the Show Network Devices display, and identify those who respond to W comms. This will effectively enable all nodes to be seen with the exception of TMN/MNC/ANC type nodes located on the internetwork. Autodialled Lans cannot be accessed.

**Controllers:** It is compatible with IQ1xx controllers version 5 and above and all IQ2xx, IQ3, IQL controllers. IQ3 web pages, and FNC/FC controllers are not supported. While the IQView will support alarms retransmitted from 962/963 it will not support alarms retransmitted from earlier supervisors (e.g. 945). It will not support IP alarms from an IQ3.

**Networks:** Current loop Lan (IQView standard version) requires network + protocol.

Ethernet 10 BASE-T connection (IQView standard version) requires an Ethernet vCNC either that provided internally within the IQView, or provided externally by either an IQ3, or an 3xtend/EINCL.

*Note that IQView with versions of firmware earlier than v1.1 could not act as a cross router master so should not be set to the lowest IP address on that Ethernet segment.*

NXIP or EINC should not be used in an automatic IP addressing environment. NXIP must not be used as a cross router master.

RS232 connects to a local controller through its supervisor port, or to a local network either using a controller's supervisor CNC (sCNC) or using a separate CNC module.

**NDP replacement:** The IQView can be used to replace an NDP. It will not physically replace a unit fitted in the cover of an IQ250, IQ251, or IQ241/242; it would have to be fitted alongside, but a blanking plate accessory is available (ACC/BLANKING PLATE/IQ25x or ACC/BLANKING PLATE:IQ24x) to blank the controller cover after removal of the NDP. It cannot physically replace a unit fitted into a panel, but an adapter plate is available to facilitate the replacement (IQVIEW/NDP ADAPTER PLATE). Also note that the IQView requires a separate input power supply (unlike the NDP which can use the controller's AUX supply). The IQView can connect to the system in a similar way to an NDP (i.e. using a controller's RS232 port RJ11, 25 Way D type, or 5 in line, or using a CNC 25 Way D type connector). *Note that the new IQView RJ11 to RJ11 (CABLE/EJ105650) or RJ11 to 25 way D type (CABLE/EJ105651) cables must be used.* The IQView does not have the following features which are present in the NDP: FNC/FC, and showing details of autodialling nodes on the internetwork.

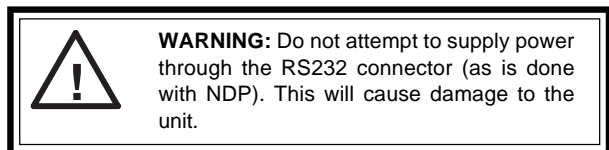

**IPTool:** IPTool (v1.4) must be used to set up the IQView's remote devices if the internetwork on Ethernet crosses router(s), and can be used to set up IP addresses if required.

# INSTALLATION

## CONNECTIONS

IQView../SM

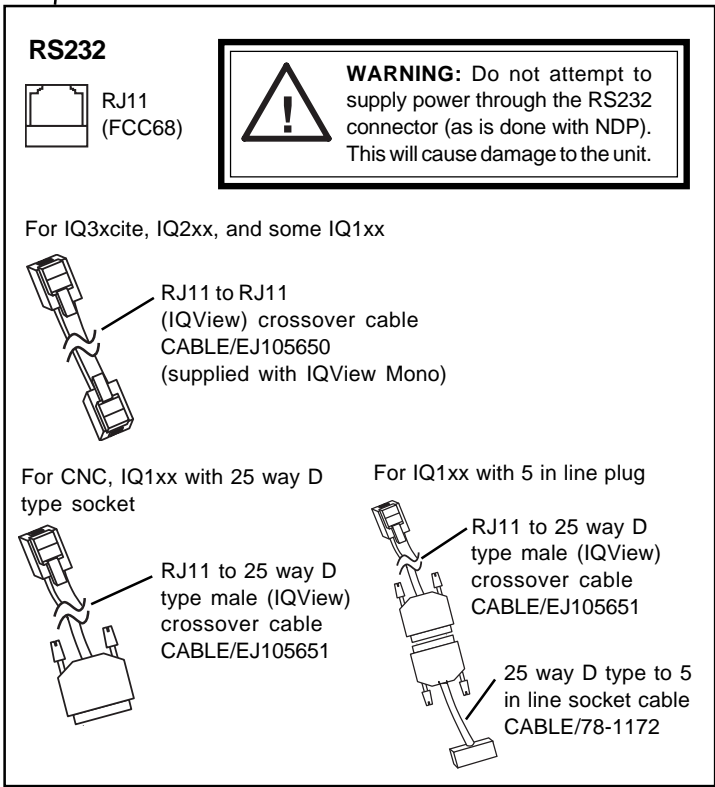
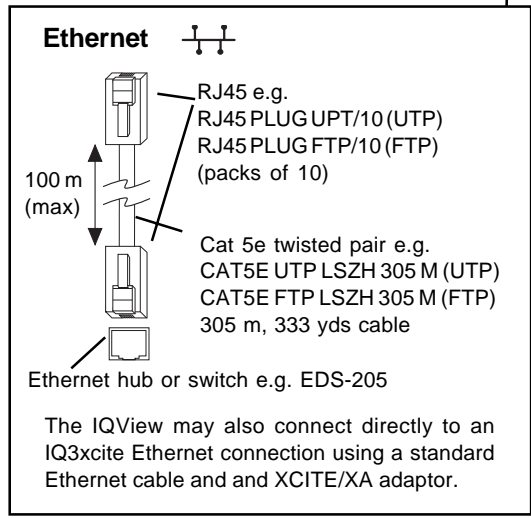
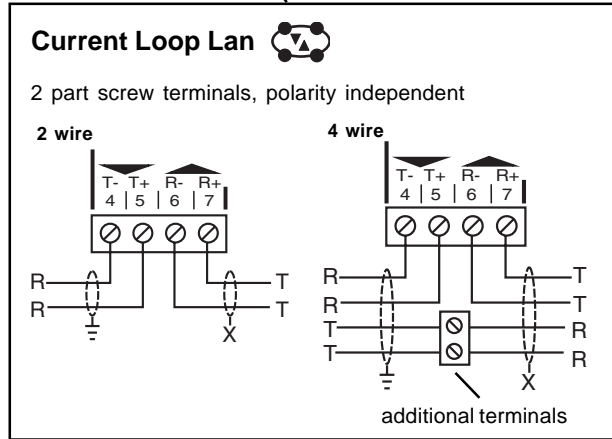
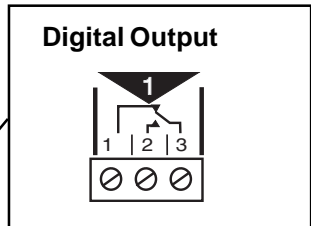
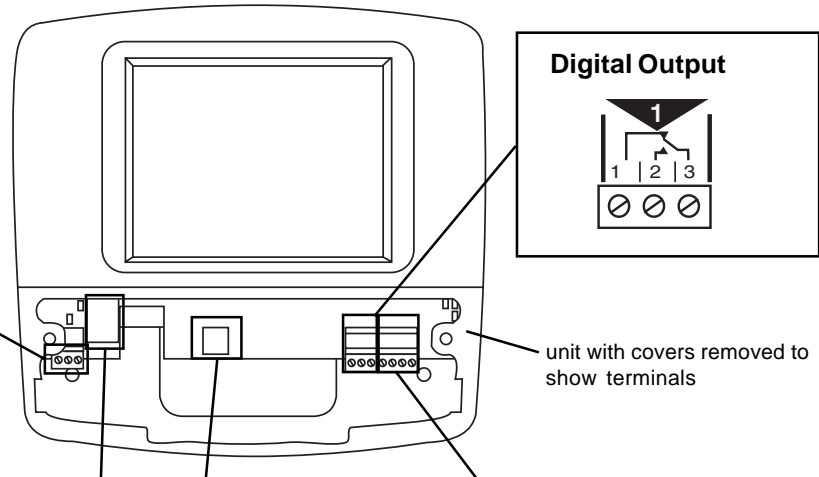
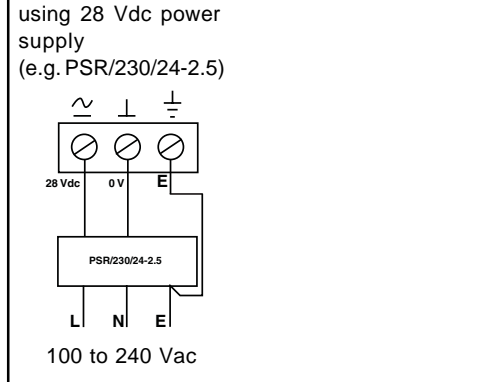
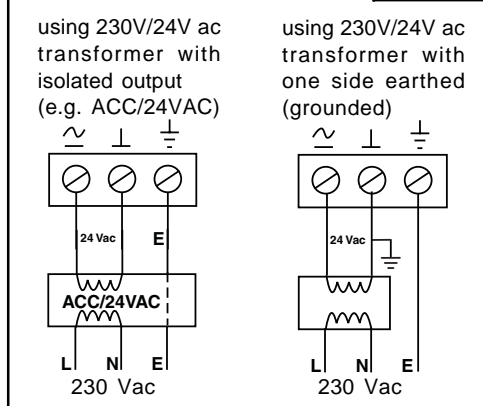
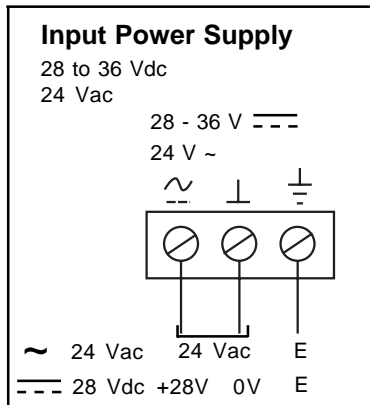

CONNECTIONS (continued)

IQView../RPM

rear view of unit

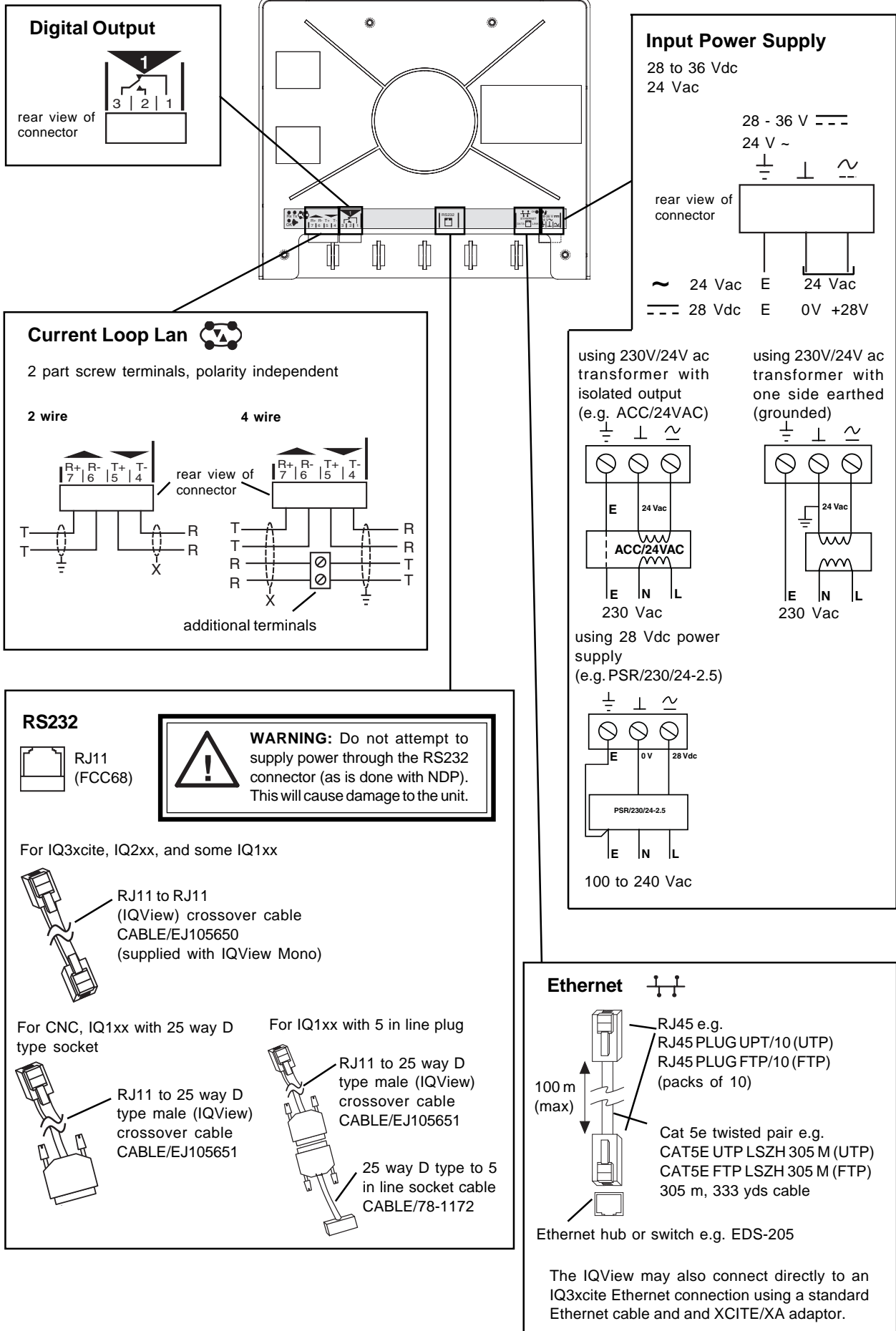

**INSTALLATION** (continued)

The surface mount version (IQVIEW../SM), is mounted on a flat surface, e.g. a wall using 3 point mounting (3 screws and rawl plugs), or a panel using 4 point mounting (4 screws screwed into the rear of unit through the panel). The rear panel mount version (IQView../RPM), is mounted behind a rectangular aperture in the panel using 4 countersunk crossheaded screws provided, and a plastic bezel is clipped over the front to hide the screwheads.

All units are UL rated as 'UL916, listed open energy management equipment'.  
The procedure involves:

- mount the unit (use template provided)
- (if replacing NDP in panel use IQVIEW/NDP ADAPTOR PLATE)
- connect power, do not power up
- connect RS232 if required
- connect Ethernet if required (not IQView Mono)
- connect current loop Lan if required (not IQView Mono)
- connect the relay output, if required
- read End User Licence Agreement (installation instructions section 3)
- power up
- configure the unit (only setting up the connection is mandatory)
- check LEDs
- test the unit

A full description of installing the surface mount version is given in the IQView../SM installation instructions TG200711, and of installing the rear panel mount version is given in the IQView../RPM installation instructions TG200712. An appropriate mounting template is provided with the unit: IQView../SM template TG200722, and IQView../RPM template TG200723. The upgrading of firmware is described in the IQView Upgrade information sheet, TG200758. The installation of the IQView/NDP adaptor plate is covered by TG200828 and the mounting template in TG200829.

**ORDER CODES**

<b>UK Order Code</b>	<b>USA Order Code</b>	
<b>IQView Mono/SM/24</b>		:Surface mounting IQView with 'Mono'* application including RJ11 to RJ11 RS232 cable.
IQView Mono/SM/USA/UL/24	882001160	:USA version of above.
<b>IQView/SM/24</b>		:Surface mounting IQView with standard* application.
IQView/SM/USA/UL/24	882001140	:USA version of above.
<b>IQView Mono/RPM/24</b>	882001170	:Rear panel mounting IQView with 'Mono'* application including RJ11 to RJ11 RS232 cable.
<b>IQView/RPM/24</b>		:Rear panel mounting IQView with standard* application.
IQView/RPM/USA/UL/24	882001150	:USA version of above.
<i>*Note that IQView Mono/ has an RS232 communications interface; IQView/ (standard) also has current loop Lan and Ethernet interfaces</i>		
<b>IQVIEW/NDP ADAPTOR PLATE</b>		:Adaptor plate to facilitate mounting an IQView/RPM in place of a panel mounted NDP.
<b>ACC/BLANKING PLATE:IQ25x</b>		:Blanking plate for removing NDP from IQ250, IQ251.
<b>ACC/BLANKING PLATE:IQ24x</b>		:Blanking plate for removing NDP from IQ241/242.
<b>CABLE/EJ105650</b>	882001310	:RJ11 plug to RJ11 plug with crossover to connect to IQ3, IQ2xx, and some IQ1xx controllers' local supervisor ports.
<b>CABLE/EJ105651</b>		:RJ11 to 25 way D type male to connect to some IQ1xx controller's local supervisor ports and to a CNC.
<b>CABLE/78-1172</b>		:25 way D type female to 5 in line socket adapter to connect to some IQ1xx controller's local supervisor ports (use in conjunction with CABLE/EJ105651).
<b>XCITE/XA/5</b>	882001100	:Pack of 5 Ethernet connector adapters for direct connection of IQView to an IQ3 using a standard Ethernet cable.
<b>ACC/24VAC</b>		:230/24 Vac, 24 VA, transformer for IQView, with surface mounting lugs, and through earth (ground) connection.
<b>PSR/230/24-2.5</b>		:A DIN rail mounted 24 Vdc power supply for supplying IQView (its output can be set to 28 Vdc).
<b>EDS-205</b>		:Unmanaged Ethernet switch with 5 off 10/100BaseT(X) ports.
<b>EDS-305-M-SC</b>		:Unmanaged Ethernet switch with 4 off 10/100BaseT(X) ports, 1 multimode100BaseFX (fibre optic) port.
<b>IMC-101-M-SC</b>		:1 channel 10/100BaseT(X) to multimode 100BaseFX (fibre optic) converter.
<b>CAT5E UTP LSZH 305M</b>		:305 m, 333 yds of Cat 5e UTP (unshielded) cable for wiring Ethernet connections.
<b>CAT5E FTP LSZH 305M</b>		:305 m, 333 yds of Cat 5e FTP (shielded) cable for wiring Ethernet
<b>RJ45 PLUG UTP/10</b>	882001120	:Packet of 10 unshielded RJ45 connector for wiring Ethernet connections.
<b>RJ45 PLUG FTP/10</b>	882001130	:Packet of 10 shielded RJ45 connector for wiring Ethernet connections.

**SPECIFICATION**

**Electrical**

CPU :Intel PXA255  
 CPU speed :200 MHz  
 Memory :16 Mbyte Flash, 32 Mbyte SDRAM  
 Input Power Supply :28 to 36 Vdc , or 24 Vac ±10%, 50/60 Hz  
 Power :24 VA maximum, 13 VA typical. The IQView consumes 13 VA, but its input power supply should be capable of 24 VA to cater for the startup current.  
 Fusing :The input supply is protected by a 6.3 A fast blow fuse.  
 Mains failure protection :User configuration data is stored in non-volatile memory (Flash). A supercap is used to maintain the real time clock (time and date); in the event of power failure this will support the clock for 24 hours minimum (at 20 °C, 68 °F). No battery required.  
 Clock accuracy :30 s per month (typical)  
 Display  
 IQView Mono :Black and white display  
 IQView (standard) :Colour (256 colours)  
 Both versions have LCD display 320 x 240 pixels (¼ VGA) STN with touch screen and digital contrast facility.  
 Backlight :Electroluminescent (CCFL) with autodim. Life 50 khrs at 20 °C (68 °F)  
 Sounder :piezo electric  
 Ethernet (not available in IQView Mono)  
 transmission distance :10/100 BASE-T autonegotiated :100 m, 109 yds to hub  
 current loop Lan (not available in IQView Mono)  
 transmission :20 mA, two wire current loop, opto-isolated, polarity independent receiver, balanced transmitter.  
 distance :between units dependent on baud rate and cable type (see below)

Cable	1k2 baud	4k8 baud	9k6 baud	19k2 baud	No. of Wires
Belden 9182	1000 m (1090 yds)	1000 m (1090 yds)	1000 m (1090 yds)	700 m (765 yds)	2
Belden 9207	1000 m (1090 yds)	1000 m (1090 yds)	1000 m (1090 yds)	500 m (545 yds)	2
<b>Trend TP/1/1/22/HF/200</b> (Belden 8761)	1000 m (1090 yds)	1000 m (1090 yds)	700 m (765 yds)	350 m (380 yds)	2
<b>Trend TP/2/2/22/HF/200</b> (Belden 8723)	1000 m (1090 yds)	1000 m (1090 yds)	500 m (545 yds)	250 m (270 yds)	4

baud rate :settable by software to 1k2, 4k8, 9k6, 19k2 baud. Set to match other nodes on Lan  
 address :settable by software to 1, 4 to 9, 11 to 119. Set to be unique on Lan.  
 RS232 port  
 transmission distance :RS232, EIA/TIA, 232E, V28 :15 m  
 baud rate :settable by software to 1k2, 4k8, 9k6, 19k2, 38k4 baud (normally 9k6). Set to match connected device.  
 Relay output :Single pole changeover relay. Can be enabled to energise when an alarm occurs. Acknowledging the alarm will close the relay. AC rating 62.5 VA (40 Vac max at 1.5 A, 24 Vac at 2.5 A). DC rating 60 W (40 Vdc max at 1.5A, 24 Vdc at 2.5 A). Note that UL rating applies up to 30 V maximum.

Indicators (only visible on surface mount version when panel removed or on rear panel mount version from rear by using mirror)  
 Power/Alarm :(Blue) ON to indicate that the input power supply is connected. Flashes if there is an alarm present. OFF indicates an input power supply failure. (This LED is visible externally on surface mount version)  
 Ethernet OK :(green) ON if the IQView has constructed a network on Ethernet with another IQ system Ethernet device (e.g. IQ3, EINC).  
 Ethernet LINK :(green) ON if the IQView has a good Ethernet connection. OFF indicates a faulty Ethernet connection  
 Ethernet RX :(yellow) Flashes when a package of data is being received from the Ethernet  
 TX :(yellow) ON if current is flowing from network transmitter  
 RX :(yellow) ON if current is entering the network receiver  
 OK (  ) :(green) ON if network is operating  
 Storage Media :SD card socket takes SD/MMC card (Secure digital/Multimedia card) for can backing up and restoring user configuration data, and upgrading the software.

**Mechanical**

Dimensions  
 /SM :227 mm (8.94") x 218 mm (8.58") x 60 mm (2.36")  
 /RPM :234 mm (9.21") x 208 mm (8.19") x 65 mm (2.56")  
 Weight  
 /SM :1.16kg, 2.55 lbs  
 /RPM :1.08 kg, 2.38 lbs  
 Connectors  
 current loop Lan :2 part connectors with screw terminals for 0.5 to 2.5 mm<sup>2</sup> cross section area (14 to 20 AWG) cable  
 relay output :2 part connectors with screw terminals for 0.5 to 2.5 mm<sup>2</sup> cross section area (14 to 20 AWG) cable  
 RS232 :RJ11 (FCC68). Connect using RJ11 to RJ11 (crossover cable) CABLE/EJ105650, RJ11 to 25 way D male CABLE/EJ105651, or CABLE/EJ105651 with 25 way D female to 5 in line male CABLE/78-1172  
 Ethernet :RJ45 connector, unshielded or shielded twisted pair (UTP or FTP) cable 10 Mbps, 100 m (109 yds), 10 BASE-T. Cable and connectors are available (see product codes). Connect local supervisor (Ethernet) through adjacent hub or directly using standard Ethernet cable and XCITE/XA adapter  
 Input Power Supply :2 part connectors with screw terminals for 0.5 to 2.5 mm<sup>2</sup> cross section area (14 to 20 AWG) cable  
 SD :Connector takes SD or MMC cards

**SPECIFICATION** (continued)**Environmental****EMC**

Emissions :EN50081-1:1992  
 EN61000-3-2:1995 + A1:1998 + A2:1998  
 EN61000-3-3:1995

Immunity :EN61000-6-2:1999

**Safety**

EJ :EN61010:2001

USA/Canada :UL rated as 'UL916 listed open energy management equipment'.

Canada :CSA22.2 No. 205-M1983 - Signal Equipment

**Ambient limits****storage**

temp :-10 °C (14 °F) to +50 °C (122 °F)

humidity :0 to 90 %RH non-condensing

**operating**

temp :0 °C (32 °F) to 45 °C (113 °F)

humidity :0 to 80 %RH non-condensing

**Protection**

/SM :IP42, NEMA3R

/RPM :IP54, NEMA3 if correctly mounted in panel

**Version**

This document covers:

Software :v1.4

**Boards**

baseboard :AP105227 issue 2

processor :AP104981 issue 1

Manufactured for and on behalf of the Environmental and Combustion Controls Division of Honeywell Technologies Sàrl, Ecublens, Route du Bois 37, Switzerland by its Authorized Representative, Trend Control Systems Limited.

Trend Control Systems Limited reserves the right to revise this publication from time to time and make changes to the content hereof without obligation to notify any person of such revisions or changes.

**Trend Control Systems Limited**

P.O. Box 34, Horsham, West Sussex, RH12 2YF, UK. Tel:+44 (0)1403 211888 Fax:+44 (0)1403 241608 [www.trend-controls.com](http://www.trend-controls.com)

**Trend Control Systems USA**

6670 185th Avenue NE, Redmond, Washington 98052, USA. Tel: (425)897-3900, Fax: (425)869-8445 [www.trend-controls.com](http://www.trend-controls.com)