

TW/..., PCW/..., XW/R/IQ Wireless Sensors and Receiver

TW/..., PCW/..., XW/R/IQ Wireless Sensors and Receiver



Description

The TW/.. wireless temperature sensors, PCW/.. wireless pulse counters, and XW/R/IQ wireless receiver provide a cost effective flexible wireless system for BMS temperature measurement and metering.

The TW/S space sensor is packaged in a standard wall mounting enclosure, whereas the TW/P HVAC equipment sensor pcb can be fitted into any of the IQ system HVAC equipment sensors (TB or TE- /O outside, /C clamp on, /I insertion). The PCW/.. pulse counters and XW/R/IQ receiver can be strapped to pipes or mounted on brackets. Up to 32 sensors can communicate with one XW/R/IQ receiver sited up to 75 m (80 yds) away (dependent on the installation environment). The XW/R/IQ plugs into an IQ2 series or IQ3 series controller's RS232 port.

Features

- Wireless technology significantly reduces installation and commissioning costs
- Sensor can be easily moved to suit changes in requirements
- Battery powered (life >=5 years)
- Up to 32 sensors to one IQ controller
- Wireless sensor repeater extends range

Physical

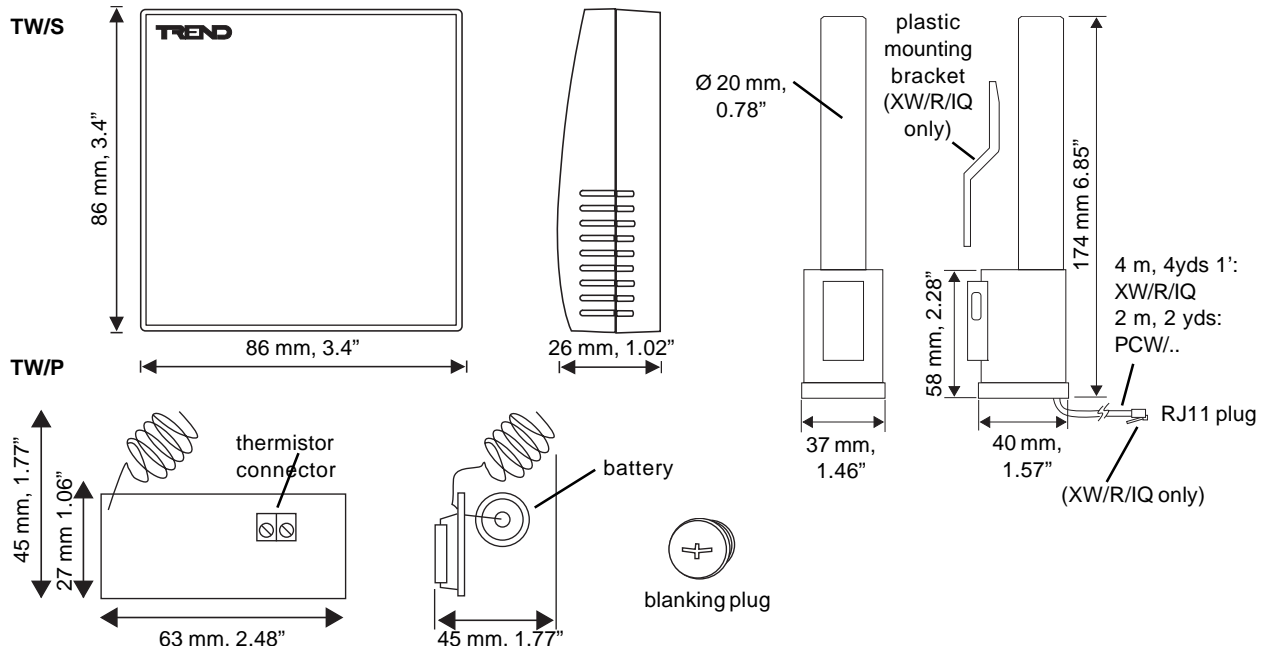

Physical (continued)

ACCW/CONFIGKIT cable
(kit also includes CD containing configuration software)

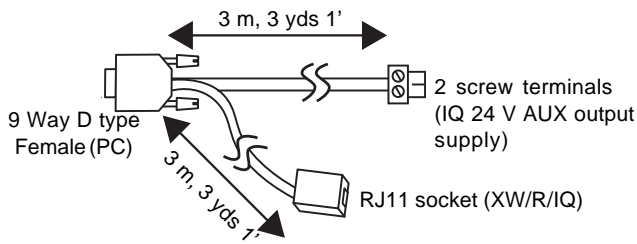

ACCW/FK/SS

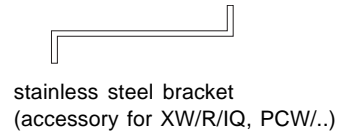

ACCW/RW/IQ (wireless sensor repeater)

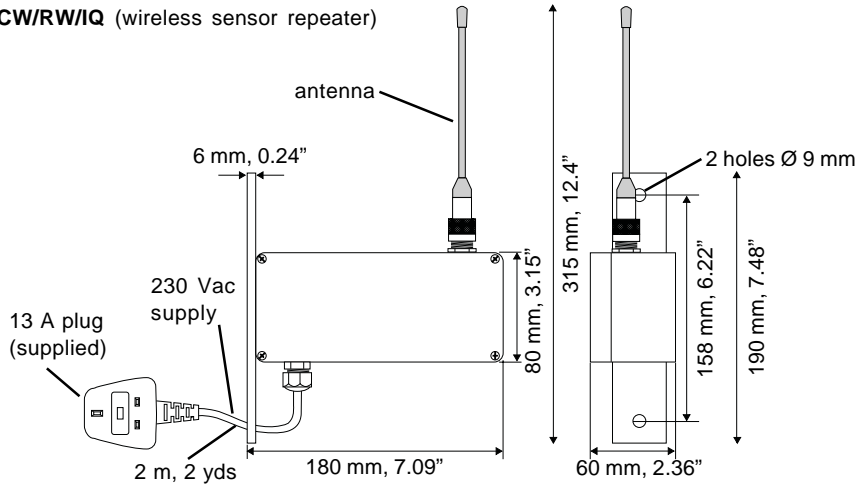

FUNCTIONALITY

The TW/.., PCW/.., XW/R/IQ wireless system consists of up to 32 wireless sensors (consisting of a mix of TW/.. and PCW/..) transmitting to an XW/R/IQ receiver. The XW/R/IQ receiver plugs into the local supervisor port of an IQ2 or IQ3 controller, and writes the sensors' values and their status to defined analogue nodes and digital points within the IQ controller.

Each wireless sensor is identified by a unique 3 byte (16,777,216 variants) number, which is printed on the sensor's identification label. Using the ACCW/CONFIGKIT configuration software, the XW/R/IQ should be programmed to allocate each identification number to an analogue node within the local IQ, or within another IQ on the local Lan. The selected analogue node has associated digital points for reception of the sensor's status

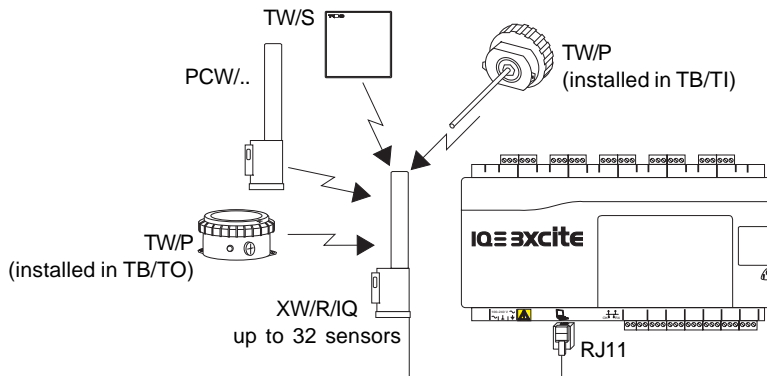

Wireless Sensors

Wireless sensors measure the required parameters and transmit them regularly to the XW/R/IQ receiver.

The sensor is powered by a lithium battery. If a low battery condition occurs, it will be indicated in the sensor's digital status bits. The batteries are not field replaceable, and when the battery has run down (voltage <3 V), the sensor should be returned to the IQ system supplier for battery replacement.

The 8 digit identifier number is printed on a label mounted on the battery of the TW/.. sensors and the surface of the PCW/.. pulse counters. A second removable label is mounted on the TW/.. sensor's pcb. and is provided for the installer's own use.

TW/S Space Sensor

The TW/S is a wall mounting thermistor space temperature sensor. The TW/S housing consists of 2 parts; front panel, and back plate, and can be either mounted onto a flat surface, or flush mounted using a standard wallbox. The two halves of the housing can be separated by inserting a broad bladed screwdriver into the lower slot and twisting.

FUNCTIONALITY (continued)

TW/P, HVAC Equipment Sensor PCB

The TW/P is a thermistor temperature sensor suitable for a field fitting to a TE/T.. or TB/T.. HVAC Equipment sensor.

- i.e. TB/TO, TE/TO outside temperature sensor
- TB/TC, TE/TC clamp on temperature sensor
- TB/TI/S, /L short and long insertion temperature sensor (for use as either immersion or duct sensor)
- TE/TE immersion temperature sensor
- TE/TD/S, /L short and long duct temperature sensor

Field Fitting: The TW/P is fitted into a TE/T.. or TB/T.. HVAC Equipment sensor by:

1. Removing lid from HVAC Equipment sensor
2. Disconnecting wires from terminal block
3. Discarding terminal block
4. Removing and discarding M20 gland, (but retaining nut)
5. Screwing blanking plug into retaining nut
6. Connecting the sensor wires to TW/P pcb
7. Inserting pcb into housing (see below)
8. Noting sensor's 8 digit identifier (and removing the second identifier label if required)
9. Closing lid

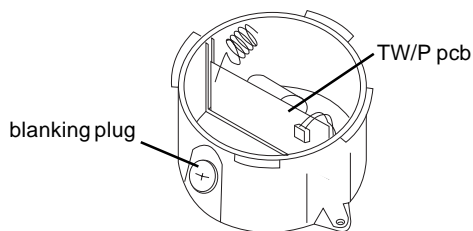

TW/P pcb mounted in HVAC equipment sensor housing

PCW/.. Pulse Counters, XW/R/IQ Receiver

The unit may be mounted using an optional stainless steel bracket (ACCW/FK/SS), or using the plastic bracket supplied with the XW/R/IQ only, or alternatively it can be tied to a pipe or other structure using a plastic cable tie.

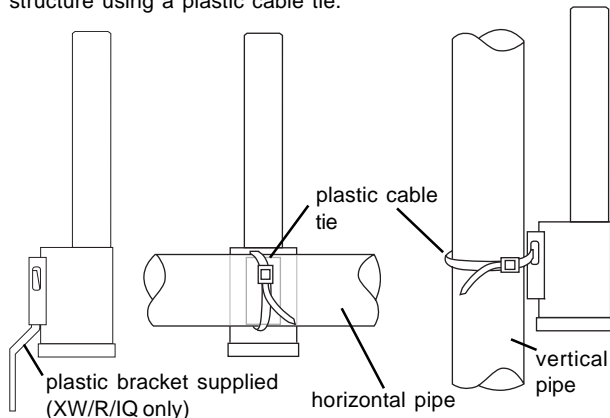

PCW/.. Pulse Counters: Whenever monitoring hot water systems it is not advisable to mount the pulse counter directly on the pipe without intervening insulation. A PCW/.. pulse counter is supplied with a 2 metre (2 yds) screened cable for connecting to the input contact.

The input may be provided by a volt free contact, opto-coupler, or transistor switch.

The PCW/.. pulse counters (/METER and /STATUS) will count the number of pulses received and transmit the accumulated value to the receiver. The count will roll round back to zero at 16777215. The PCW/METER sends the value every minute and is compatible with receivers of serial number 2404701 and greater.

The PCW/STATUS also sets one of its status bits to the state of the input. It is designed to monitor non-fleeting inputs; the state must last longer than 5s. It sends the value and status on change of input state and every 4 minutes. The PCW/STATUS is compatible with receivers of serial number 2505157 and greater.

XW/R/IQ receiver: The XW/R/IQ receiver is supplied with a 4 m (4 yds 1') screened cable for connecting to an IQ controller. If a longer distance is required (up to 15 m, 16 yds), then an RJ11 extension cable may be used. The receiver is powered from the controller.

Optimum range will only be achieved if the antenna is kept clear of metallic objects such as water tanks and other conducting surfaces.

Transmission

The transmitters will transmit in a short burst approximately as follows:

- TW/S:** every 2 minutes
- TW/P:** every 1½ minutes
- PCW/METER:** every 1 minute
- PCW/STATUS:** every 4 minutes, and on change of input state with a triple burst (with 1s separation).

In between transmissions they will switch into low power 'sleep' mode.

The transmission consists of the sensor identifier, the value, and the sensor's status.

Each XW/R/IQ receiver must be programmed with a 32 entry internal look-up table of its associated sensors.

	Transmitter Address	Analogue Node No.	O/S Address
Entry	00698624	A201	8

Each entry in the table associates a sensor with the XW/R/IQ receiver and references the sensor's 8 digit identifier to both its target analogue node, and its target outstation.

Note that the nodes used will have to be created in the strategy for IQ3 controllers (they always exist in IQ2xx controllers).

Normally the outstation number will be the device address of the outstation to which it is connected, but it may be the address of another outstation on its local Lan. If it uses another outstation then the local outstation's proxy CNC must be set up (i.e. the local supervisor port address must be non-zero).

The sensor sends its status bits to the receiver: all sensors send battery fail status, TW/.. sensors send the sensor fail status, and the PCW/STATUS sends the input state. The receiver will also detect if the sensor is failing to update within 15 mins, and generate a loss of reception status. The receiver produces the sensor status bits.

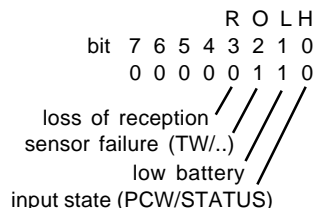

On receipt of a value from the controller the receiver will send the sensor value to the analogue node and outstation address set up in appropriate entry in the look-up table, and it will send the status bits to the alarm byte associated with that node in IQ2 and IQ1 series controllers (e.g. A200 uses byte 240 by convention - see IQ Digital/Analogue Array Reference Card, TB100522)

For IQ3 controllers the analogue node has to be created when engineering the strategy. The four status outputs, Read (R), Outside Limits (O), Low (L), High (H) corresponding to the status bits (3 to 0 respectively) are provided in the analogue node module (see compatibility section).

The status bits are sent to the local controller using text comms (if transmitting to another controller, IC Comms will be used).

FUNCTIONALITY (continued)

Reception

The recommended maximum range between a wireless sensor and the XW/R/IQ receiver is 75 metres (80 yds).

All sensors transmit on the same frequency band (433.05 to 434.79 MHz).

Propagation

The signal propagation within the building also depends on :

- Reflection from flat surfaces such as metal cladding, galvanized roofing, foil backed plaster board.
- Radiation from thin conductors such a pipe work, electrical wiring, steel.
- Reflection and re-transmission can result in a standing wave being set up in the area. If the receiver happens to be in a null of the wave, moving its position slightly will result in stronger reception.
- Absorption by lossy materials such as damp concrete, stone work, and people. High RF barriers are paper (e.g. books), concrete (floors, outer walls), and metal (elevator shafts, cabinets).

Generally, the higher the transmitter is mounted, the further the signal will reach. It is recommended to mount the transmitter above partition height if possible.

Interference

It is not recommended that other equipment operating over the same frequency band be used in the same environment (e.g. amateur radio). It is also advisable to keep the wireless sensors and XW/R/IQ away from other sources of interference e.g. computer (>1 m, 1 yds), microwave ovens, switch mode power supplies.

ACC/RW/IQ Repeater

The repeater can be used to increase the maximum distance between a transmitter and the receiver. Thus, if the repeater is placed within 75 metres (80 yds) of the transmitter, the receiver can then be 75 metres (80 yds) from the repeater which increases the total distance from the transmitter to the receiver to 150 metres (160 yds).

In a white walled building (a building with rooms thermally insulated with foam and aluminium sheets; food industry) best performance may be found by mounting the repeater in the loft space above the white walled area. There will always be a degree of leakage in a white walled building, and propagation is much easier out of the room, in a loft space, compared to between white walls.

Enclosure: The repeater is supplied in a compact diecast wall mounting enclosure. The bracket supplied should be used to secure the unit to a wall such that the antenna is vertically polarised.

Input Power: The repeater requires 230 Vac 50 Hz at <1W. It is supplied with a flying 230 Vac power cable with a standard 13 A fused plug.

The repeater contains a half duplex radio port. It has an intelligent store and repeat function, holding the address and message counter of the repeated message, and barring them from repeat within a given time window in the event of a second repeater being within range. New messages with a changed address or message count will be repeated. Messages not obeying the correct protocol, or with corruption, or with checksum failure will not be repeated.

Network identification

Note that the XW/R/IQ will not respond to w comms (i.e. it will not identify itself as a networked device when polled).

Configuration

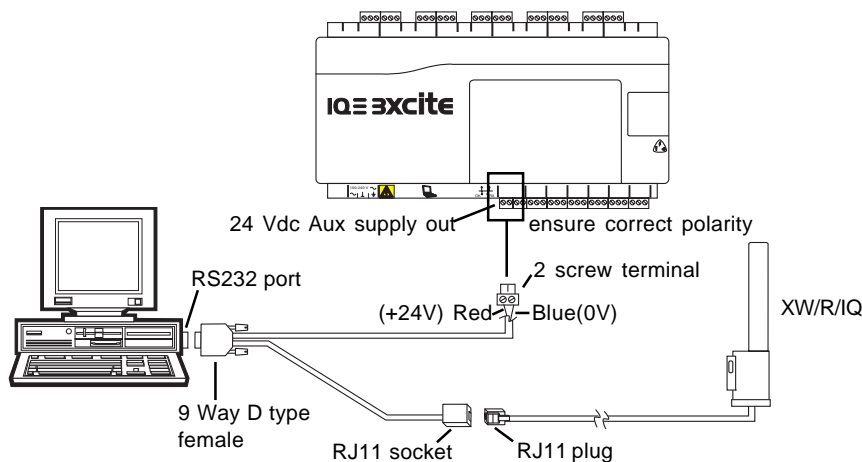

The XW/R/IQ receiver must be configured before completing the installation. This is done using the ACCW/CONFIGKIT configuration kit consisting of a CD containing the XW/R/IQ configuration software and the configuration cable (EJ105784).

The software should be installed on a PC, and the XW/R/IQ connected to the PC's RS232 port using the configuration cable.

The adaptor cable has 3 connectors, a 9 way D type female for connecting to the PC's RS232 port, an RJ11 socket for connecting to the XW/R/IQ, and a 2 screw terminal plug for connecting to an IQ's 24 Vdc auxiliary output supply.

FUNCTIONALITY (continued)

The configuration software will be installed in Program files/Project1 by default. It will appear in the Start/Programs menu as Rtcom-Trend/Rtcom-Trend. Once the program is started it will display the following page.

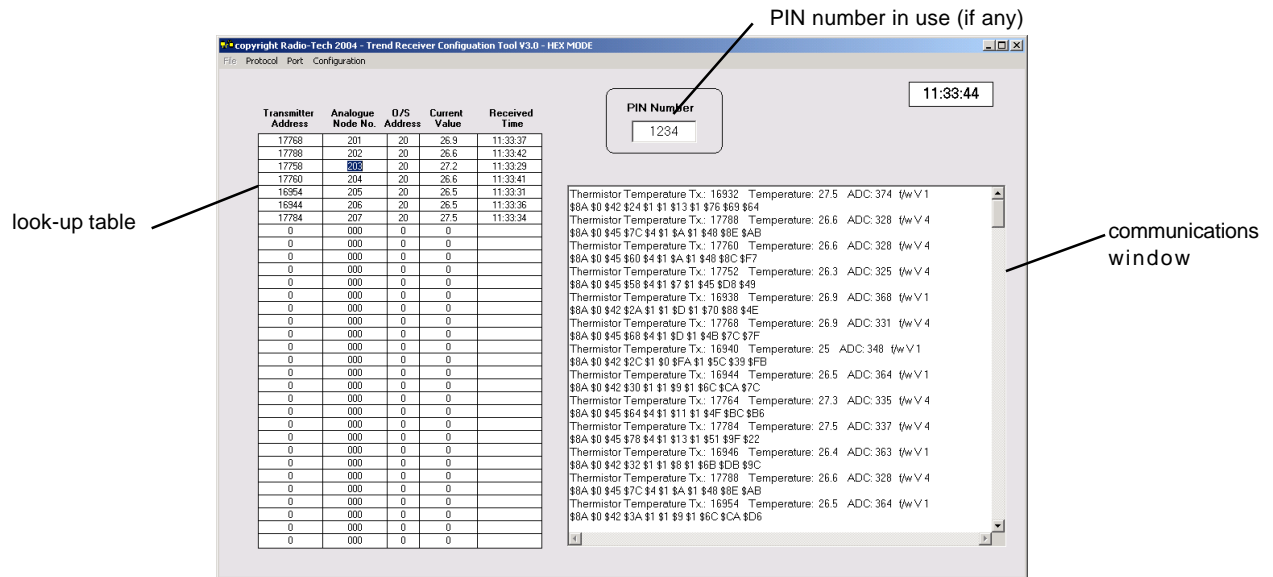

The configuration software enables the look-up table stored in the XW/R/IQ to be configured. There are 32 rows in the table, one for each sensor entry. Each row in the table has the following parameters.

1. Transmitter Address: An 8 digit identification number, unique to each transmitter (e.g. 00016932 will be displayed as 16932). The identification number is shown on a label attached to the wireless sensor.
2. Analogue Node Number: This is the node within the IQ controller to which the sensor's value will be written. It must be configured.
3. Outstation Address: This is the controller address on the local Lan. It is normally the address of the local controller, but it can be the address of another controller on the local Lan. A value of zero is invalid and will cause that sensor entry to be delivered.

Note that the sensor value is then sent to the address, analogue node xx in IQyy (xx is an analogue node number, yy is a O/S address).

If the value is to be sent to another controller then the local controller's local supervisor port address must be set greater than zero.

4. Current value: The last value received from the sensor; the value is transmitted every 2 minutes (for TW/S), every 1 minute (for TW/P, PCW/METER), and every 4 minutes (for PCW/STATUS; plus on every input change).

Note that for PCW/METER or PCW/STATUS the initial value should be recorded as it will vary from unit to unit. The pulse counter has been designed not to have reset capability in order to prevent fraud.

5. Received Time: The time the last value was received from the sensor.

The full configuration details are covered by the XW/R/IQ Configuration Software Manual, but the sequence given below covers the main steps:

1. The XW/R/IQ receiver and its wireless sensors should be installed according to their installation instructions.
 2. On the 'Protocol' menu ensure that the 'Trend Protocol' option is selected (✓).
 3. On the 'Port' menu select the port number of the RS232 port to which the XW/R/IQ is connected; the selected port number will then be indicated by a tick (✓).
 4. If the controller has a password set up, specify a PIN in the XW/R/IQ that matches one of priority level 95 or greater set in the controller. On the 'Configuration' menu select 'Program PIN Number' and enter the PIN. If the controller does not have a password set up, then on the 'Configuration' menu select 'disable PIN code'.
- Note that if the sensor values are to be sent to several controllers then all these controllers must have the same password setup (>=level 90).*
5. To check the existing configuration table within the XW/R/IQ, on the 'Configuration' menu select 'Read Channels 1-16'; this will display the information in the first 16 entries in the table. Then 'Read Channels 17-32' to read the information in the last 16 entries.
 6. The configuration menu may be amended or cleared and set up from scratch. The available sensors can be found from the communications window; on the 'Configuration' menu select Output Mode and '0 - All transmitters [binary]'. This will change the communication display into a more legible format. It will show the communications from all the sensors that the XW/R/IQ can receive.

FUNCTIONALITY (continued)

Each communication shows the Address (identification number) of the sensor and its current value:

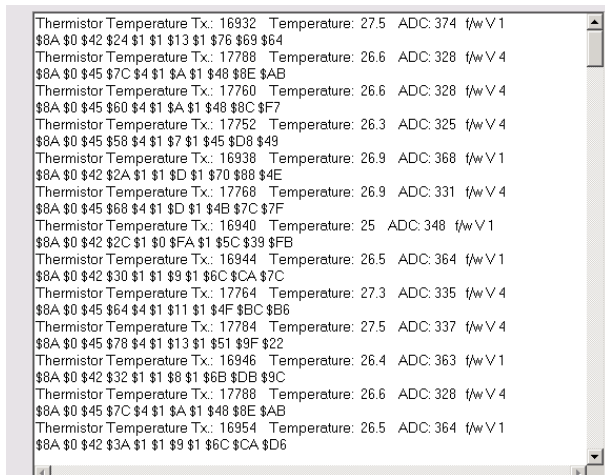

Communications window when set to: '0 - All transmitted (binary)'

Thermistor Temperature TX: 16940 Temperature: 27.7 ADC: 376 f/w V4
 \$8A \$0 \$42 \$2C \$1 \$1 \$15 \$1 \$78 \$9 \$E9
 sensor address

Choose a sensor address from the available sensors stored in the communications window and type its details into the next available row in the table.

e.g.	Transmitter Address	Analogue Node No.	O/S Address	Current Value
	16940	204	21	

Once the address is entered, moving the cursor to the 'Analogue Node No.' will cause the number to change to the next node in sequence (i.e. increment the node number from the node above). Moving the cursor to the O/S address will cause it to default to the same O/S address as the row above.

The value received from the sensor will then be entered into the current value position.

- On the 'Configuration' menu select 'Output Mode' and '5 - Programmed Transmitters Trend Protocol [ASCII]'

CAUTION

Ensure that the menu item 'Configuration/Output mode' is setback to '5 - Programmed Transmitter Trend Protocol (ASCII)' or the receiver will not operate.

- On the 'Configuration' menu select 'Program Channels 1-16' to write the first 16 items of the configuration table, and then select 'Program Channels 17-32' to write the last 16 entries. This will program the XW/R/IQ receiver with the new table.
- On the 'Configuration' menu select 'Read Channels 1-16' and then select 'Read Channels 17-32' to check that the table is correct.
- Plug the XW/R/IQ receiver into its IQ controller.

Multiple Sensors and Receivers

XW/R/IQ receivers will receive communications from all wireless sensors within range (nominally 75 metres, 80 yds, but this can be affected by the installed environment and by the use of repeaters). Thus in the diagram below both XW/R/IQ receivers will receive from all wireless sensors 1, 2, and 3.

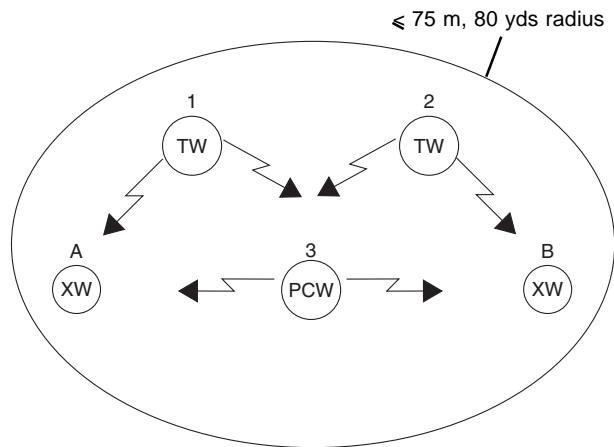

The system configuration engineer can decide how the XW/R/IQ receivers can be configured to select which wireless sensors each of them receives.

If the engineer wishes, a wireless sensor can be received by more than 1 receiver; this will enable the same value to be present in 2 controllers, hence a degree of redundancy can be provided. Alternatively the value may be sent from controller to controller by IC comms.

COMPATIBILITY

Controllers: The XW/R/IQ is compatible with IQ2xx controllers and all IQ3's. The standard XW/R/IQ relies on the IQ controller to supply its power from the RS232 local supervisor RJ11 socket. This is available on all current IQ2s and IQ3s except for the IQ251.

Connection to an IQ251 (or any other IQ2 without 24 V output supply available on its RJ11) requires the use of the additional adaptor cable RD/SDU-ADAPTOR IQ2xx.

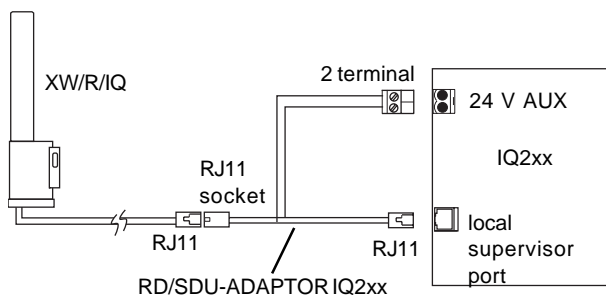

Note that if fitting to a controller, the local supervisor port should not already be in use (i.e. by SDU-IQ or SDU-xcite, RD-IQ, IQView/RS232, NDP, or local PC), and the 'sUperv port addr' should be set to zero (default).

Note that the XW/R/IQ is not compatible with /ADL, /ATM or XNC220 controllers as the RS232 port is already in use.

NOTE that the PCW/METER pulse counter is only compatible with XW/R/IQ receivers of serial number 2404701 and greater, and that the PCW/STATUS is only compatible with XW/R/IQ receivers of serial number 2505157 and greater.

COMPATIBILITY

When used with IQ3 any analogue nodes used have to be created using SET. An example strategy for a wireless sensor input is given below. The sensor failure status (TW/.. only) and loss of reception status are passed through the internal sensor module, but the battery low status and the digital input status (PCW/STATUS only) are monitored separately by internal digital inputs.

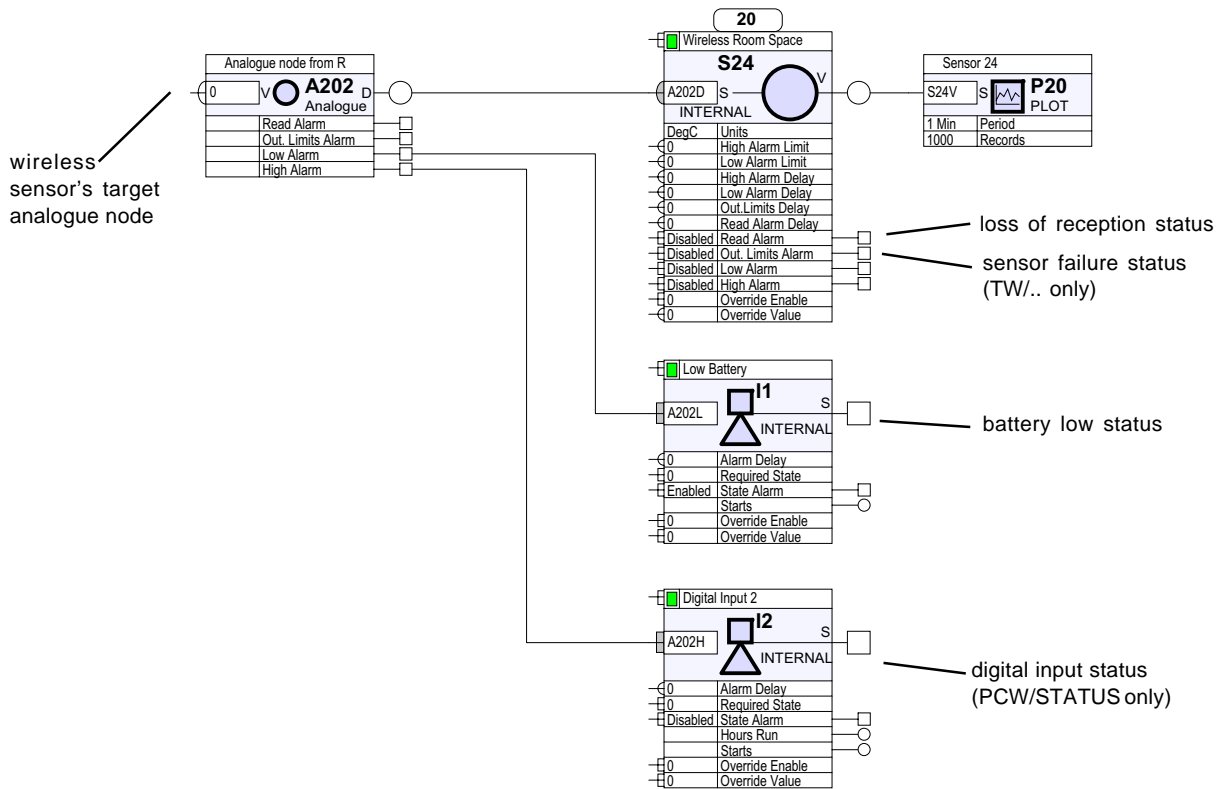

INSTALLATION

Note that the location of the sensor and receiver should be carefully chosen with consideration given to the interference given in the reception section above. Mount the units as high as possible. The maximum distance for a sensor from its receiver is 75 m (80 yds) or 150 m (160 yds) with a centrally placed repeater.

TW/S

- Choose location
- Mount Sensor (using 2 screws - minimum)
- Note sensor identification number
- Assemble sensor unit

ACCW/RW/IQ (repeater)

- Choose location (install within 75 m, 80 yds, of sensor and 75 m, 80 yds, of receiver)
- Mount on wall using bracket (supplied)
- Plug in 230 Vac supply and switch on power.

TW/P

- Choose location and TB HVAC equipment sensor type
- Remove lid from HVAC equipment sensor
- Disconnect and remove connector
- Remove M20 gland and fit blanking plug
- Connect TW/P to thermistor leads
- Note sensor identification number
- Close lid
- Install HVAC equipment sensor according to its installation instructions

Test System

The installation details are covered by the following documents:

- TW/S Installation Instructions TG200781
- TW/P Installation Instructions TG200782
- PCW/... Installation Instructions TG200834
- XW/R/IQ Installation Instructions TG200783
- XW/R/IQ Configuration Tool Manual TE200793
- ACCW/RW/IQ Installation Instructions TG200852

PCW/...

- Choose location
- Mount using bracket or cable ties
- Note sensor identification number

The installation of the TB HVAC equipment sensors are covered as follows:

- TB/TC, /TI, /TO Data Sheet TA200724
- TB/TO Installation Instructions TG200725
- TB/TC Installation Instructions TG200726
- TB/TI Installation Instructions TG200727

XW/R/IQ

- Choose location
- Mount receiver using bracket or cable ties
- Configure receiver using ACCW/CONFIGKIT
- Plug receiver into controller
- (In IQ3 configure analogue nodes to receive values)

CONNECTIONS

TW/S



wireless sensor requires no connections

TW/P (e.g. TB/TI)

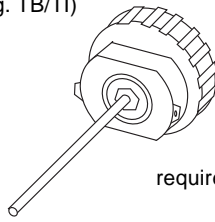

wireless sensor requires no connections

PCW/...

volt free contact

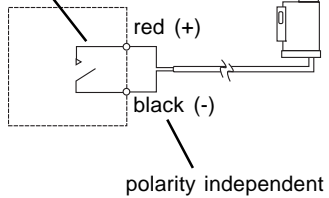

transistor or opto-coupler

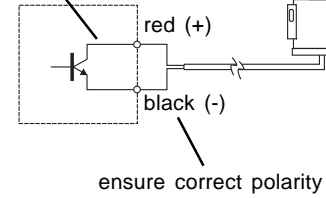

XW/R/IQ

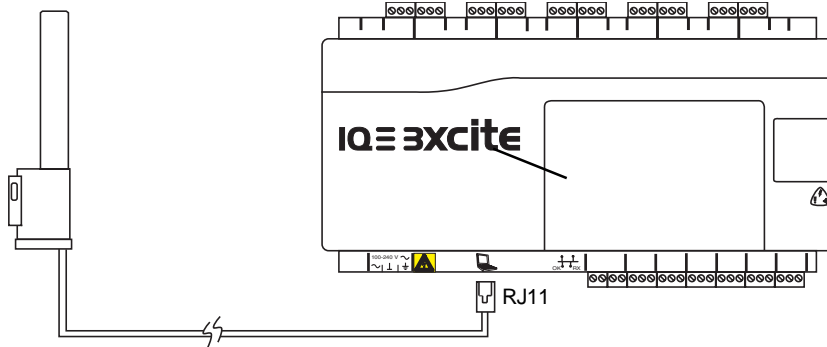

IQ3xcite or current
IQ2xx (except
IQ251)

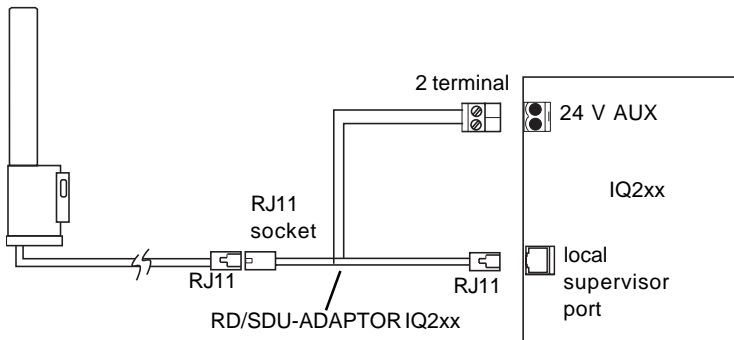

IQ251 or older IQ2xx without
24 V supplied through RJ11

ACCW/RW/IQ

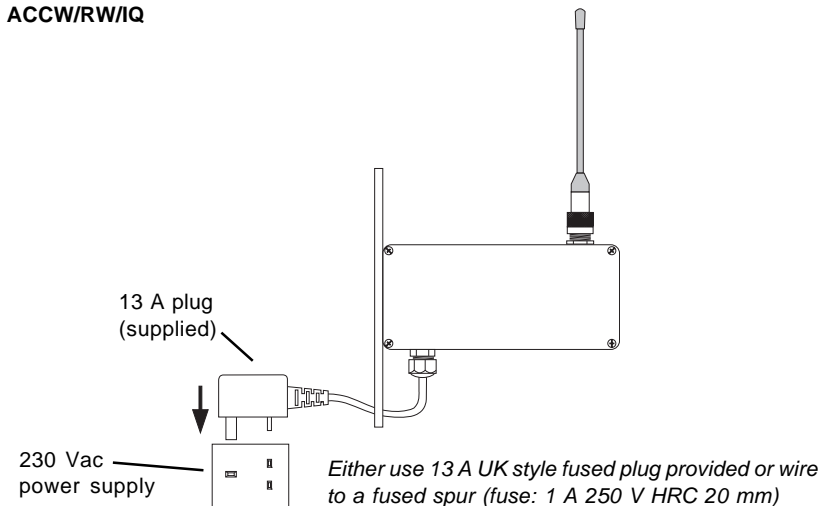

MAINTENANCE

The only maintenance required is for the battery in the wireless sensors. It has a minimum life of 5 years. If the battery runs down the XW/R/IQ receiver will set an alarm bit in the status data sent with the value. This corresponds to Bit 1 (Low alarm). When the battery has run down, the unit should be returned to your IQ system supplier for battery replacement.

DISPOSAL

COSHH (Control of Substances Hazardous to Health - UK Government Legislation 2002) ASSESSMENT FOR DISPOSAL OF SENSOR AND RECEIVER. The only part affected is the lithium battery (in the sensor) which must be disposed of in a controlled way.

RECYCLING.

All plastic and metal parts are recyclable. The printed circuit board may be sent to any PCB recovery contractor to recover some of the components for any metals such as gold and silver.

WEEE Directive :



At the end of their useful life the packaging, product, and batteries should be disposed of by a suitable recycling centre. Do not dispose of with normal household waste. Do not burn.

ORDER CODES

TW/S	Wireless space sensor
TW/P	Wireless HVAC equipment sensor pcb and blanking plug for M20 gland for post fit into TB HVAC equipment sensor housing
PCW/METER	Pulse counter wireless sensor
PCW/STATUS	Pulse counter wireless sensor with digital input status reporting
ACCW/RW/IQ	Wireless sensors repeater
XW/R/IQ	Wireless sensor receiver with plastic wall bracket
ACCW/CONFIGKIT	Programming kit for XW/R/IQ including connection cable between receiver, PC, and input power supply, and CD containing configuration software
RD/SDU-ADAPTOR IQ2xx	Adaptor cable for connecting XW/R/IQ to IQ251 and other earlier IQ2xx controllers which do not have 24 Vdc supplied through the RJ11 local supervisor port
ACCW/FK/SS	Stainless steel wall bracket for mounting XW/R/IQ at a distance of 28 cm from wall

SPECIFICATION

Electrical

Transmission frequency:	UHF 433.05 to 434.79 MHz (wide band FM)
Transmission range	:>=75 m, 80 yds (in open field) 150 m, 160 yds, with repeater (ACCW/RW/IQ)
Battery	:(TW sensors) Lithium 3.6 V2/3 AA, leaded (i.e. not plug-in) (PCW/...) Lithium 3.6V C Cell Both factory replacement only
Battery life	
TW/..	:>5 years
PCW/...	:>7 years
Input power	:(XW/R/IQ) 24 Vdc ±10% at 50 mA (from RS232 in IQ3 or current IQ2xx excluding IQ251; from AUX 24 Vdc output supply in IQ251 or older IQ2xx without 24 V supplied through RJ11)
Normal output power	:< 10 mW, <0.1% duty cycle
Transmission interval	
TW/S	:2 minutes
TW/P	:1½ minutes
PCW/METER	:1 minute
PCW/STATUS	:4 minutes (plus on input status change)
TW/Measurement Range:	:-30 to +110 °C (-22 °F to +230 °F)
TW/.Resolution	:0.1 °C (0.18 °F)
Input	
Pulse rate	:(PCW/... only) 10/s maximum (100 ms pulse length minimum)
Duration	:(PCW/STATUS only) Input state must be longer than 5s.

Mechanical

Dimensions	
TW/S	:86 x 86 x 26 mm (3.4" x 3.4" x 1.02")
TW/P	:board 63 x 45 x 45 mm (2.48" x 1.77" x 1.77")
XW/R/IQ, PCW/...	:174 x 37 x 40 mm (6.85" x 1.46" x 1.57")
Material	
TW/S	:Enclosure, Flame retardant (V0) ABS
XW/R/IQ, PCW/...	:Polypropylene
Colour	
TW/S	:White
PCW/...	:Blue
XW/R/IQ	:White
Environment	
Temperature:	
TW/S	:-10 to +50 °C (14 to +122 °F)
TW/P	
TB/.. enclosure	:-40 to +50 °C (-40 to +122 °F)
TB/TC probe	:-30 to +100 °C (-22 to +212 °F)
TB/TI probe	:-30 to 110 °C (-22 to +230 °F)
XW/R/IQ	:-35 to 70 °C (-31 to +158 °F)
PCW/...	:-35 to 60 °C (-31 to +140 °F)
Humidity	
TW/S	:0 to 95 %RH non-condensing
TW/P (TB/ enclosure):	0 to 95 %RH non-condensing
XW/R/IQ, PCW/...	:0 to 100 %RH

Environment protection

XW/R/IQ, PCW/...	:IP68+
TW/P	:IP67 (in TB enclosure)
TW/S	:IP20
Standards	
CE	:434 MHz
Radio	:EN-300-220-1, MPT1601

ACCW/RW/IQ Repeater

Transmission frequency:	UHF 433.05 to 434.79 MHz (wide band FM)
Transmission range	:>=75 m, 80 yds (in open field)
Input Power	:230 Vac, 50 Hz, <1W
Transmit power	:<= +10 dBm
Antenna connector	:N-type 50 ohms
Dimensions	:180 x 80 x 60 mm, 7.09" x 3.15" x 2.36" (excluding bracket, connections, and antenna) :315 x 80 x 60 mm, 12.4" x 3.15" x 2.36" (including bracket, connections, and antenna)
Material	:Enclosure, Diecast aluminium grey painted.
Protection	IP675 (when sealed)
Environment	
Temperature	:-20 °C to +55 °C (+4 °F to +99 °F)
Standards	
Safety	:EN60950 (2000)
Approval	:EN-300-220-3 (Cetacom, Belgium, Notified Body Number 0682, R&TTE Directive April 2000)

Manufactured for and on behalf of the Environmental and Combustion Controls Division of Honeywell Technologies Sàrl, Ecublens, Route du Bois 37, Switzerland by its Authorized Representative, Trend Control Systems Limited.

Trend Control Systems Limited reserves the right to revise this publication from time to time and make changes to the content hereof without obligation to notify any person of such revisions or changes.

Trend Control Systems Limited

P.O. Box 34, Horsham, West Sussex, RH12 2YF, UK. Tel:+44 (0)1403 211888 Fax:+44 (0)1403 241608 www.trend-controls.com

Trend Control Systems USA

6670 185th Avenue NE, Redmond, Washington 98052, USA. Tel: (425)897-3900, Fax: (425)869-8445 www.trend-controls.com