

Installation Instructions - Fixing

PNC2

Printer Node Controller



Important: Retain these instructions

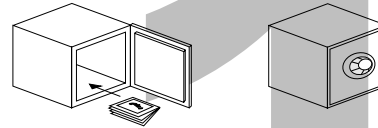

CONTENTS

1.1 Unpacking	1 - 1	1.3 Installation Instructions - Fixing	1 - 1
1.2 Storage	1 - 1	2.1 Installation Instructions - Configuration	2 - 1
		2.2 Connecting to LRM	2 - 3

SHEET 1: Installation Instructions - Fixing

1.1 Unpacking

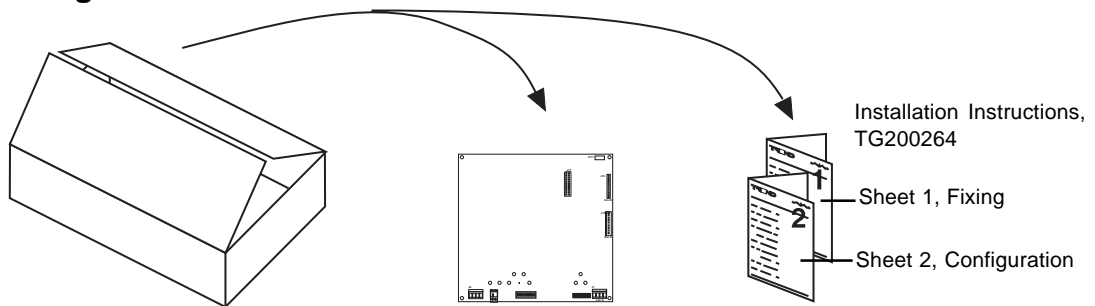

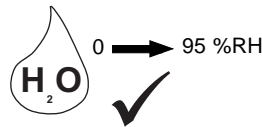
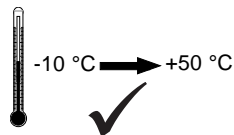

1.2 Storing

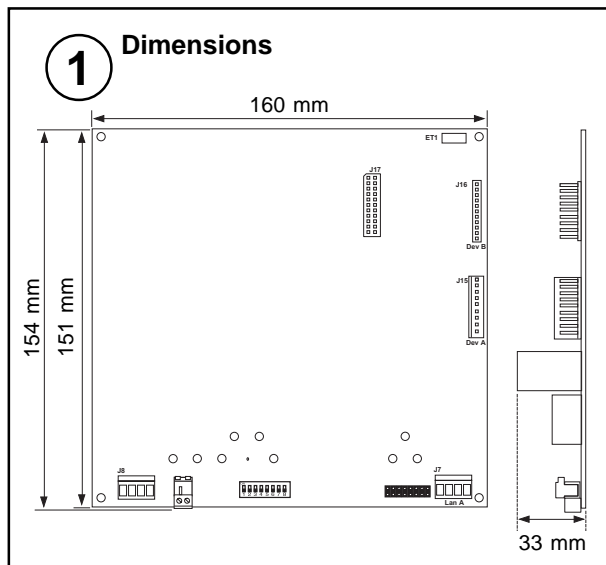

1.3 Installation - Fixing



 It is recommended that the installation should comply with the HSE Memorandum of Guidance on Electricity at Work Regulations 1989.

WARNING:  Opening the panel may expose dangerous voltages.
417-IEC-5036

Caution:  The PNC2 contains static-sensitive devices. Suitable anti-static precautions should be taken throughout this operation to prevent damage to the unit.
BS EN100015/1 Basic Specification: protection of electrostatic sensitive devices.

1.3 Installation - Fixing (continued)

2 Requirements

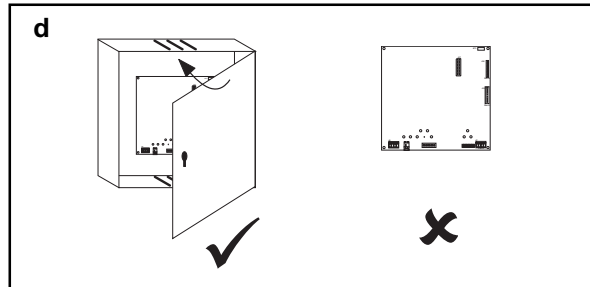
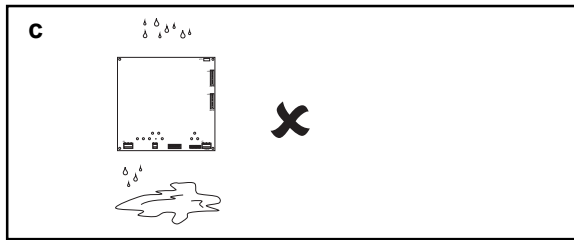
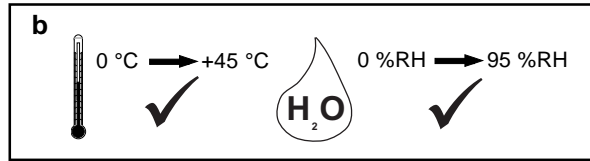
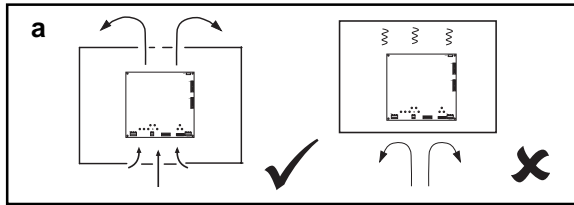

3 Mount the Node

The PNC2 can be fitted into enclosures and controllers as shown in the table below:

NETB/NETBB	✓
IQ101+/102+	✓
IQ111+	✓
IQ131+	✓
IQ251	✓*
IQ250	✓*
IQ241/242	✓
IQ231/233	✓

* PNC2 board fits with 3 screws in normal node position or fits in NDP position (if no NDP). Must use NDP position if RDS fitted.



See appropriate enclosure/controller installation instructions for more details about node installation.

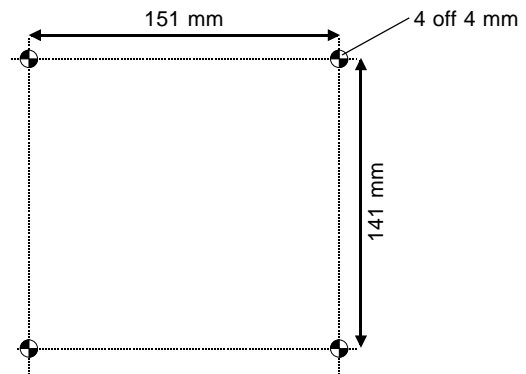

4 Connecting Power

PNC2 consumption ≤ 5 VA

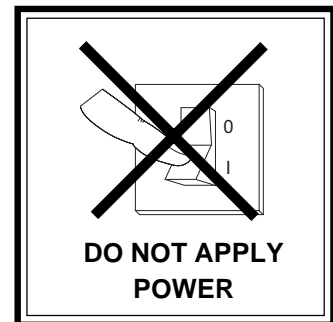
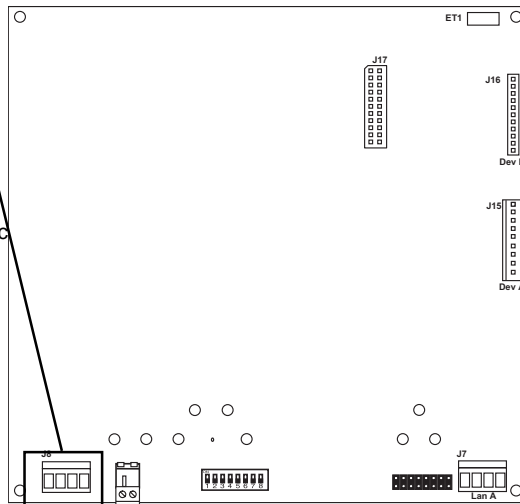
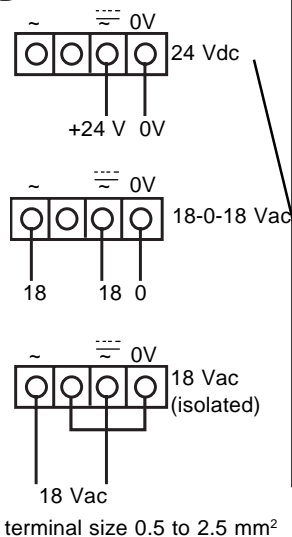

1.3 Installation - Fixing (continued)

5 Connecting Earth

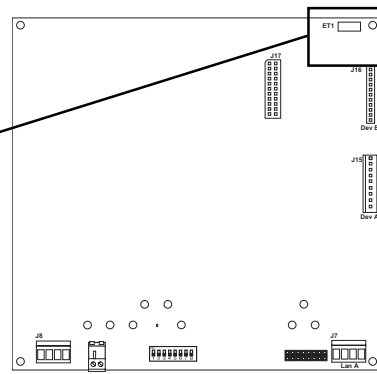
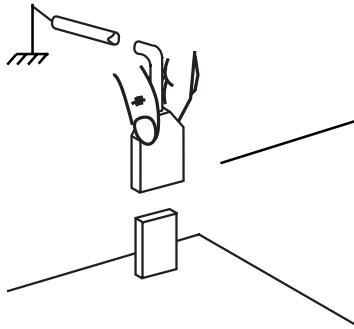

WARNING: This apparatus must be earthed

6 Connect Network (Lan A)

Network Engineering Manual, 92-1735

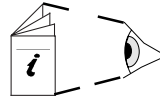

Cable	1k2 baud	4k8 baud	9k6 baud	19k2 baud	No. of Wires
Belden 9182	1000 m	1000 m	1000 m	700 m	2
Belden 9207	1000 m	1000 m	1000 m	500 m	2
IQ system TP/1/1/22/HF/200 (Belden 8761)	1000 m	1000 m	700 m	350 m	2
IQ system TP/2/2/22/HF/200 (Belden 8723)	1000 m	1000 m	500 m	250 m	4

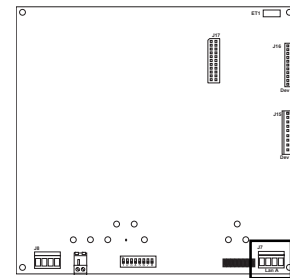

terminal size 0.5 to 2.5 mm²

Polarity independent

2 wire

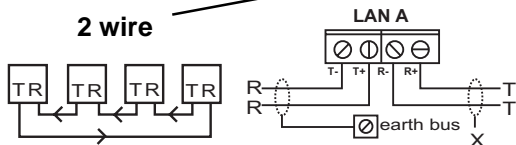

4 wire

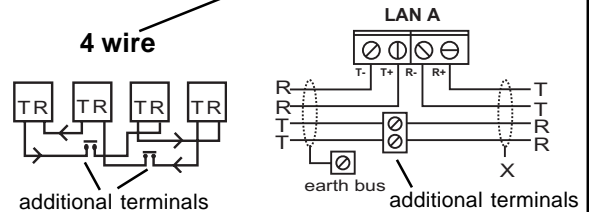

7 Select Printer
(Device B - RS232)

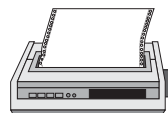

Printer must:

- Be able to accept Epson type control codes
- Have an RS232 serial interface with following settings:
 Baud Rate: 19k2, 9k6, 4k8 or 1k2
 Serial/Parallel: Serial
 Comms type: either 8 bits no parity
 or 7 bits odd parity
 Auto Line Feed: On

The PNC2 must have its baud rate and comms type set accordingly, see PNC2 installation instructions Sheet 2: Configuration steps 5 and 6

1.3 Installation - Fixing (continued)

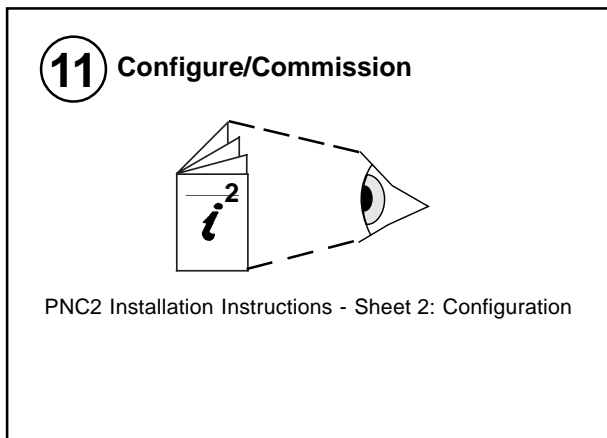
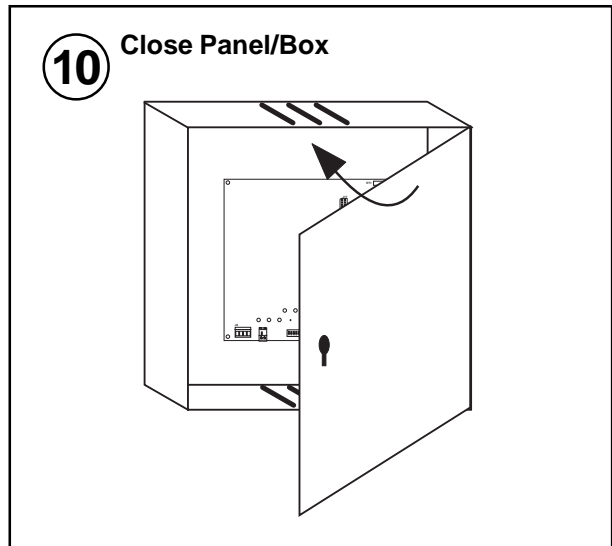
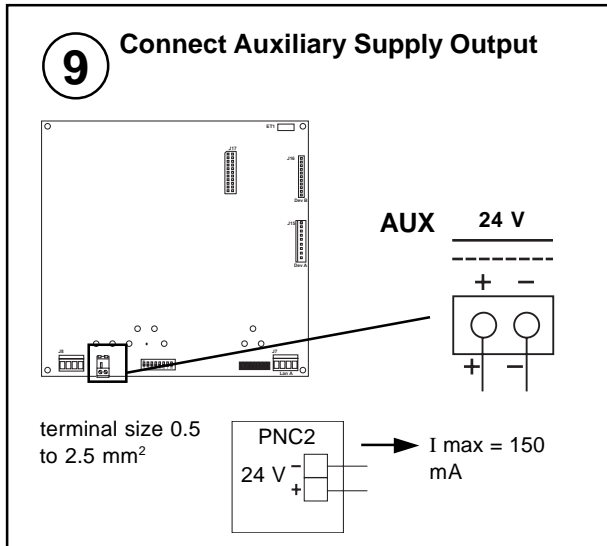
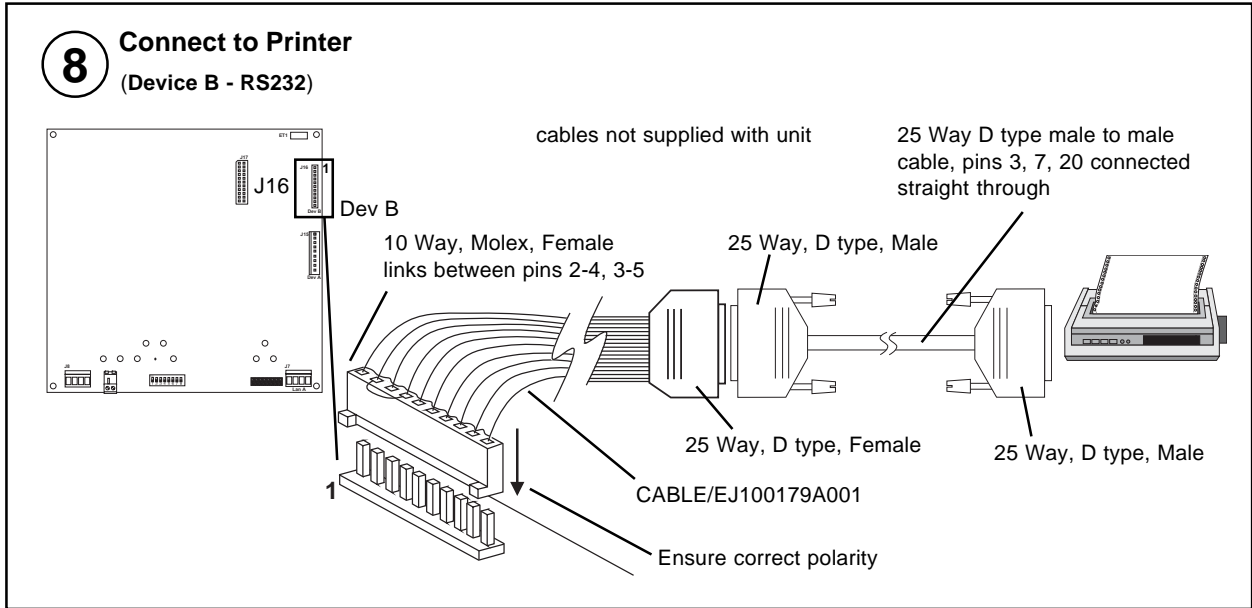

PNC2

Printer Node Controller



SHEET 2: Installation Instructions - Configuration

2.1 Installation - Configuration

1 Fix Unit

PNC2 Installation Instructions - Sheet 1: Fixing

2 Switch off and open panel/ covers

WARNING: Opening the panel may expose dangerous voltages. 417-IEC-5036

Caution: The PNC2 contains static sensitive devices. Suitable anti-static precautions should be taken throughout this operation to prevent damage to the unit.

BS EN100015/1 Basic Specification: protection of electrostatic sensitive devices.

3 Set the Network Address (Lan A)

e.g.

1	2	4	8	16	32	64	NORM
↑	↑	↑	↑	↑	↑	↓	
ADDRESS							

Address = 2+16+64= 82

Address = D

SET (switch down) / NOT SET (switch up)

address ✓ 1, 4 to 9, 11 to 114
✗ 0, 2, 3, 10 or >119

4 Set Network Baud Rate (Baud A)

move link to set baud rate

Network Baud Rate = R1

e.g 9k6

5 Set Device B connector (RS232) to Printer Baud Rate (Baud B)

move link to set baud rate

Device B (J16) to printer Baud Rate = R2

2.1 Installation - Configuration (continued)

6 Set Dumb/Normal switch to Printer Comms Type

e.g. ADDRESS: 1, 2, 4, 8, 16, 32, 64

DUMB
Sets Printer Comms Type to:
8 bits no parity

Norm
Sets Printer Comms Type to:
7 bits odd parity

7 Switch On

8 Check Node Controller

(a) PWR ON (green) ✓
✗ Check supply

(b) ! W/DOG (red) ✓
✗ PNC2 Faulty

9 Check Network

RXA (yellow) ✓
✗ ?

TXA (yellow) ✓
✗ ?

OKA (green) ✓
✗ Network Address Invalid 0, 2, 3 or >119

LAN A: ✗ PNC2 Faulty
✓

OKA (green) ✓
✗ Check network cabling for short circuits with a multimeter (NOT Megger)

✗ Check baud rate
Power up other nodes until faulty node is found (OK (green)). Correct fault.

2.1 Installation - Configuration (continued)

10 Close panel/covers

11 Set up printer

Set printer RS232 serial interface as follows:
 Baud rate set as step 5 above (1k2, 4k8, 9k6, or 19k2)
 Comms type set as step 6 above
 either 8 bits no parity
 or 7 bits odd parity
 Auto Line Feed: On

12 Configure Alarm Language
 if required

The PNC2 will automatically set its alarm language to that of the other nodes on the local Lan if possible (otherwise stays in English). It may be changed if required:

Recommend use of PowerTool or Wupdn

IQ Configuration Manual 90-1533
 PNC2 Data Sheet TA200263
 PowerTool Manual TE200163
 Wupdn Manual TE200162

Set language by **R(P=x)**
 where x defines language as follows:
x=0 English, =1 Spanish, =2 Finnish, =3 Swedish, =4 Norwegian, =5 Danish, =6 German, =7 Italian, =8 Portuguese, =9 French.

Note that if the PNC2 is reset by power up or on change of address or baud rate, the PNC2 will automatically set its language

13 Check System

2.2 Connecting to LRM

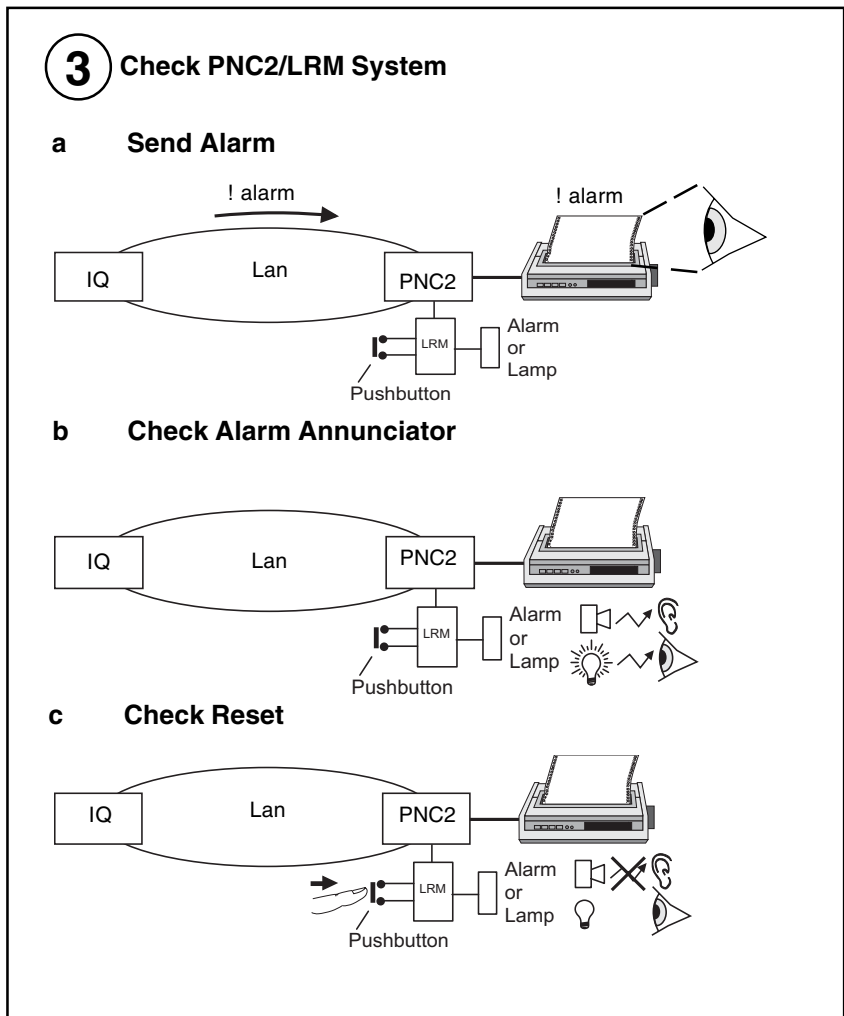
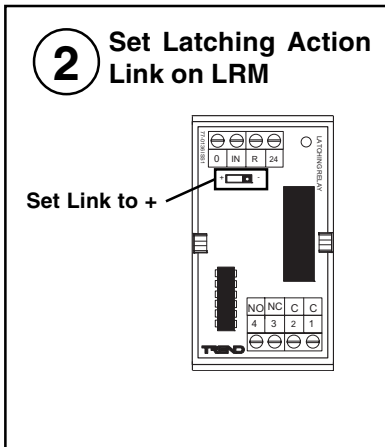
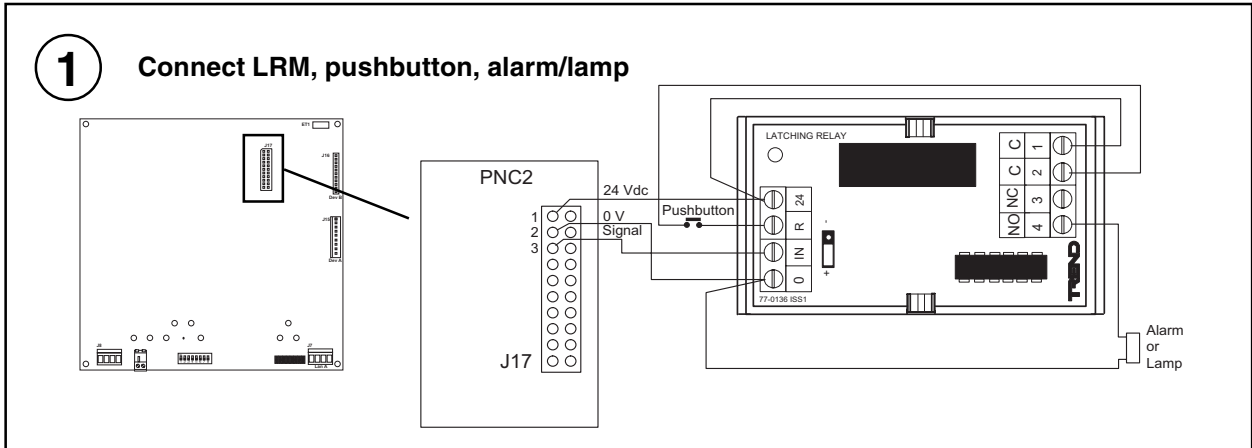

Trend Control Systems Ltd reserves the right to revise this publication from time to time and make changes to the content hereof without obligation to notify any person of such revisions or changes.

TREND	P.O. Box 34, Horsham, West Sussex, RH12 2YF United Kingdom		Website www.trend-controls.com
	Telephone +44 (0)1403 211888	Fax (International) +44 (0)1403 210982	Fax (UK) +44 (0)1403 241608
E-mail trendinfo@novar.com		Registered office. Novar House 24 Queens Road Weybridge Surrey KT13 9UX Registered in England No 1664519	